

Recognized as an
American National Standard (ANSI)

ANSI C63.17-1998

American National Standard for Methods of Measurement of the Electromagnetic and Operational Compatibility of Unlicensed Personal Communications Services (UPCS) Devices

Sponsor

Accredited Standards Committee on Electromagnetic Compatibility, C63

Accredited by the

American National Standards Institute

Secretariat

Institute of Electrical and Electronics Engineers, Inc.

Approved 5 February 1998

American National Standards Institute

Abstract: Specific test procedures are established for verifying the compliance of unlicensed personal communications services (UPCS) devices with applicable regulatory requirements regarding radio-frequency (RF) emission levels and spectrum access procedures.

Keywords: etiquette, personal communications, RF emissions, spectrum access, unlicensed devices

The Institute of Electrical and Electronics Engineers, Inc.
345 East 47th Street, New York, NY 10017-2394, USA

Copyright © 1998 by the Institute of Electrical and Electronics Engineers, Inc.
All rights reserved. Published 1998. Printed in the United States of America

ISBN 1-55937-965-0

No part of this publication may be reproduced in any form, in an electronic retrieval system or otherwise, without the prior written permission of the publisher.

American National Standard

An American National Standard implies a consensus of those substantially concerned with its scope and provisions. An American National Standard is intended as a guide to aid the manufacturer, the consumer, and the general public. The existence of an American National Standard does not in any respect preclude anyone, whether he has approved the standard or not, from manufacturing, marketing, purchasing, or using products, processes, or procedures not conforming to the standard. American National Standards are subject to periodic reviews and users are cautioned to obtain the latest editions.

CAUTION NOTICE: This American National Standard may be revised or withdrawn at any time. The procedures of the American National Standards Institute require that action be taken to reaffirm, revise, or withdraw this standard no later than five years from the date of publication. Purchasers of American National Standards may receive current information on all standards by calling or writing the American National Standards Institute.

Authorization to photocopy portions of any individual standard for internal or personal use is granted by the Institute of Electrical and Electronics Engineers, Inc., provided that the appropriate fee is paid to Copyright Clearance Center. To arrange for payment of licensing fee, please contact Copyright Clearance Center, Customer Service, 222 Rosewood Drive, Danvers, MA 01923 USA; (508) 750-8400. Permission to photocopy portions of any individual standard for educational classroom use can also be obtained through the Copyright Clearance Center.

Introduction

[This introduction is not part of ANSI C63.17-1998, American National Standard for Methods of Measurement of the Electromagnetic and Operational Compatibility of Unlicensed Personal Communications Services (UPCS) Devices.]

In November 1993, the Federal Communications Commission (FCC) invited the Accredited Standards Committee on Electromagnetic Compatibility, C63, “to consider development of standard measurement procedures to support” proposed new provisions to Part 15 of volume 47 of the Code of Federal Regulations (47 CFR 15) for unlicensed personal communications services (UPCS) devices. At its December 1993, meeting, Accredited Standards Committee C63 established a subcommittee (SC 7) to attempt to develop such standards in cooperation with representatives of the WINForum and other interested parties. This document is the result of the efforts of that committee.

At the time it approved this standard, the Accredited Standards Committee on Electromagnetic Compatibility, C63, had the following members:

Ralph M. Showers, Chair

Edwin L. Bronaugh, Vice Chair

Tricia Gerdon, Secretary

<i>Organization Represented</i>	<i>Name of Representative</i>
Aeronautical Radio, Inc. (ARINC).....	Dan Martinec
Alliance for Telecommunications Industry Solutions	Paul Prisaznuk (<i>Alt.</i>)
American Automobile Manufacturers Association	John F. Lichtig
American Council of Independent Laboratories.....	O. J. Gusella (<i>Alt.</i>)
American Radio Relay League	Terry Rybak
Apple Computer.....	Barbara Wendling (<i>Alt.</i>)
Association of American Railroads	Ross A. Hansen
Association of Telecommunications Attorneys.....	Walter Poggi (<i>Alt.</i>)
AT&T Bell Laboratories.....	Hugh Turnbull
Computer and Business Equipment Manufacturing Association	Edward F. Hare (<i>Alt.</i>)
EEI/Electric Light & Power Group	Bill C. Wong
Electronic Industries Association	Chris Allman
ESD Association.....	Glen Dash
Federal Communications Commission.....	Jon Curtis (<i>Alt.</i>)
Food and Drug Administration.....	H. Robert Hofmann
Health Industry Manufacturers Association	William T. Rhoades
Hewlett-Packard.....	William F. Hanrahan (<i>Alt.</i>)
Institute of Electrical and Electronics Engineers, Inc.....	Gary N. Miller (<i>Alt.</i>)
Kaman Science Corporation	Ralph Justus
National Association of Broadcasters.....	Douglas C. Smith
National Electrical Manufacturers Association	L. Art Wall
National Institute of Standards and Technology.....	Richard B. Engleman
National Telecommunications and Information Administration	Hugh L. Van Tuyl (<i>Alt.</i>)
Radio Shack	Paul S. Ruggera
Siemens ROLM	Jeffrey L. Silberberg (<i>Alt.</i>)
Society of Automotive Engineers	Eric V. Anderson
	Randall L. Anderson (<i>Alt.</i>)
	Ray Magnuson
	Edwin L. Bronaugh
	Donald N. Heirman
	Nestor Kolcio
	Arthur Heath Light
	Kelly Williams
	William J. Murphy
	Kenneth Gettman (<i>Alt.</i>)
	Motohisa Kanda
	Karl Nebbia
	Mac Slayton
	Stephen Berger
	Herbert K. Mertel
	Poul Andersen

<i>Organization Represented</i>	<i>Name of Representative</i>
Southwest Research Institute	James J. Polonis Willaim E. Cory (<i>Alt.</i>)
Telecommunications Industry Association.....	Eric J. Schimmel
TUV Product Service.....	Daniel D. Hoolihan Tim O'Shea (<i>Alt.</i>)
Underwriters Laboratories	Willard Tuthill Corey Hyatt (<i>Alt.</i>)
Unisys Corporation	Wallace Amos
University of Oklahoma, EMC Center	Hank Grant Robert Schlegel (<i>Alt.</i>)
US Air Force.....	John Zentner Dennis Baseley (<i>Alt.</i>)
US Dept. of Energy-Bonneville Power Administration	Vernon L. Chartier
US Dept. of Energy-Oak Ridge National Laboratory.....	Paul Ewing Richard A. Hess (<i>Alt.</i>)
US Dept. of Energy-Western Area Power Administration.....	Scott E. Johnson
US Dept. of the Army, Communications Electronic Command.....	David Cofield
US Dept. of the Navy, Space and Naval Warfare Systems Command.....	Stephen Caine Marcus Shellman (<i>Alt.</i>)
US Dept. of Transportation -Federal Aviation Administration	Robert Frazier
Violette Engineering	J. L. Norman Violette Michael F. Violette (<i>Alt.</i>)
WIN Forum.....	Anatoly Tsaliovich
Members-at-Large	Ralph Calvecchio Robert J. Eagan Richard B. Schulz Ralph M. Showers

At the time this standard was approved, SC 7, the subcommittee that prepared this standard, had the following active membership:

A. Heath Light, Chair
Jay Padgett, Document Editor

Anatoly Tsaliovich, Vice Chair
John McKown, Secretary

Stephen Berger	Phillip Inglis	Larry Nutting
Greg Czumak	Don Johnson	David Steer
Franz Gisin	Kwai Lum	Terrence E. Sterkel
John Hirvela	Peter Murry	Koon Hoo Teo

The following persons were on the balloting committee that approved this standard for submission to the American National Standards Institute:

Chris Allman	Donald Heirman	William T. Rhoades
Wallace Amos	Robert H. Hoffman	Paul Ruggera
Eric Anderson	Daniel D. Hoolihan	Terry Ryback
Poul Anderson	Scott Johnson	Eric J. Schimmel
Edwin L. Bronaugh	Ralph Justus	Richard B. Schulz
Steve Caine	Motohisa Kanda	Ralph M. Showers
Ralph Calvacchio	Nestor Kolcio	Jessie M. Slayton
Vernon L. Chartier	John F. Lichtig	Douglas C. Smith
David Cofield	A. Heath Light	Anatoly Tsaliovich
Myron Crawford	Ray Magnuson	Hugh Turnbull
Glen Dash	Dan Martinec	Willard Tuthill
Robert J. Eagan	Herbert K. Mertel	J.L. Norman Violette
Richard B. Engleman	Gary N. Miller	Art Wall
Paul Ewing	William J. Murphy	Bill Wong
Robert Frazier	Karl Nebbia	John Zentner
Ross Hansen	Ravi Ravindran	Kelly Williams

Adam Sicker
IEEE Standards Project Editor

Contents

1.	Introduction.....	1
1.1	Scope.....	1
1.2	Applications.....	1
1.3	Road map to the standard.....	2
2.	References.....	2
3.	Definitions, acronyms and abbreviations, and symbols.....	3
3.1	Definitions.....	3
3.2	Acronyms and abbreviations.....	6
3.3	Symbols.....	7
4.	Radiated and conducted test methodology.....	7
4.1	Test facilities and equipment.....	7
4.2	Test configurations and setup.....	8
4.3	Transmitted power and monitoring threshold limits.....	10
4.4	Conducted measurements of products with collocated transmitting and monitoring antennas of the same type.....	11
4.5	Conducted measurements of products with collocated transmitting and monitoring antennas of different types.....	11
4.6	Conducted measurements of products with arbitrarily placed transmitting and monitoring antennas.....	11
4.7	Radiated measurements of products with collocated transmitting and monitoring antennas of the same type.....	12
4.8	Radiated measurements of products with collocated transmitting and monitoring antennas of different types.....	12
4.9	Radiated measurements of products with arbitrarily placed transmitting and monitoring antennas.....	13
5.	Measurement instrumentation.....	13
5.1	Antennas.....	13
5.2	Digital storage oscilloscope.....	13
5.3	Frequency counter.....	14
5.4	Low-noise amplifier.....	14
5.5	Modulation analyzer or frequency and time-interval analyzer.....	14
5.6	Alternative instrumentation.....	15
5.7	Square-notch interference generator.....	15
5.8	Multicarrier interference generator.....	15
5.9	Power meter.....	16
5.10	Pulse/arbitrary waveform generator.....	16
5.11	Signal generator.....	17
5.12	Spectrum analyzer.....	17
5.13	Complex waveform analyzer.....	18
5.14	Antenna calibration.....	19
6.	RF measurements.....	19

6.1	Emissions test	19
6.2	Frequency and time stability	26
7.	Monitoring tests	28
7.1	Introduction.....	28
7.2	Calibration of sensitivity	31
7.3	Threshold level	34
7.4	Threshold monitoring bandwidth.....	37
7.5	Isochronous reaction time and monitoring interval	38
7.6	Asynchronous spectrum access procedures	40
8.	Time and spectrum window access procedure	44
8.1	Time and spectrum window selection	44
8.2	Isochronous timing tests	51
9.	Test report	55
9.1	Test report contents.....	55
9.2	Applicable standards	55
9.3	Equipment units tested.....	55
9.4	Test configuration	55
9.5	List of test equipment	55
9.6	Units of measurement	55
9.7	Location of test site.....	55
9.8	Measurement procedures	56
9.9	Reporting measurement data	56
9.10	General and special conditions	56
9.11	Summary of results	56
9.12	Required signatures.....	56
9.13	Test report appendixes	56
9.14	Test report disposition	56
Annex A (informative)	47 CFR 15, Subpart D—Rules and test cases for unlicensed PCS	57
Annex B (informative)	Notes on alternative monitoring procedure	67
Annex C (informative)	Power spectral density.....	68
Annex D (informative)	Radiated and conducted measurement of power output and monitoring thresholds.....	76
Annex E (informative)	Monte Carlo routine for asynchronous back-off time distribution	82
Annex F (informative)	Guidelines for using out-of-operating-region interference	84

American National Standard for Methods of Measurement of the Electromagnetic and Operational Compatibility of Unlicensed Personal Communications Services (UPCS) Devices

1. Introduction

1.1 Scope

This standard sets forth uniform methods of measurement of the electromagnetic and operational compatibility of unlicensed personal communications services (UPCS) devices. This standard does not cover licensed personal communications services (PCS) devices. The recommended methods described are applicable to the radio transmitter and monitoring devices contained in the UPCS device. These methods apply to the measurement of individual UPCS devices. Additional methods may be added to this standard to fulfill future requirements.

In addition to the measurements specified herein, UPCS devices may also be required to be tested in accordance with other standards. Examples are listed in Annex A.

1.2 Applications

The procedures given herein may be used to test UPCS devices permitted under 47 CFR 15, Subpart D. The emissions and operational characteristics of UPCS devices are the basic parameters affecting UPCS coexistence with other electronic devices and systems. In particular, compliance with this standard may be used to demonstrate electromagnetic compatibility with other isochronous and asynchronous UPCS systems, the private operational/fixed microwave services systems, and other systems operating in the same and adjacent frequency bands.

This standard describes preferred test methods and facilities and, in some cases, alternative test methods and facilities. If these methods and facilities do not apply to the equipment under test (EUT), the manufacturer shall explain why and shall provide an alternative test procedure that has been approved by the applicable regulatory agency. If alternative test methods or facilities are employed, every effort should be made to establish a correlation with the preferred methods or facilities.

Where the word *shall* is used in this document, it indicates something that is mandatory for compliance with this standard. The word *should* indicates something that is advisory only.

1.3 Road map to the standard

The tests for UPCS devices fall into two categories. The first category includes the traditional radio frequency (RF) measurements of radiated power, emission mask, power spectral density, etc. These tests are given in Clause 6 of this document. The second category includes tests for the channel monitoring and access requirements unique to UPCS devices. These requirements are sometimes collectively referred to as the spectrum etiquette. The associated tests are described in Clauses 7 and 8 of this document, and they relate to Sections 15.321 (asynchronous devices) and 15.323 (isochronous devices) of 47 CFR 15, Subpart D. These sections of 47 CFR 15, Subpart D, require that a UPCS device monitor the received RF power level on the intended transmit channel¹ before transmitting, and provide criteria that the monitored power level shall satisfy to allow the device to transmit on that channel. The tests in Clauses 7 and 8 are designed to verify compliance with these requirements. Annex A provides a table showing the sections in 47 CFR 15, Subpart D, that correspond to the tests in this standard.

To test for compliance with the monitoring and access requirements, it is necessary to subject the EUT to deliberate interference, with controlled spectral and temporal characteristics on a selected channel or channels, and to observe the reaction of the EUT. To restrict operation of the EUT to the selected channel(s), interference can be used to block the other channels. Use of administrative commands to facilitate testing (e.g., to restrict operation of the EUT to the desired channels) is also acceptable; however, test results obtained by using actual interference to block the unused channels take precedence in the event of a difference in results.

Clauses 6, 7, and 8 give the fundamental tests. Clause 4 discusses test methodology for both radiated and conducted RF emission, monitoring, and access tests. Annex D provides the theoretical background. Radiated tests measure field strength to determine the effective isotropic radiated power (EIRP), energy density, and out-of-band emissions (see Clause 6). For the monitoring and access tests of Clauses 7 and 8, a calibrated field strength is applied to the EUT, if radiated measurements are used. If all EUT antennas are detachable, the tests of Clauses 6, 7, and 8 shall be done on a conducted basis (i.e., RF connections can be made between the EUT, its companion device, and the RF measuring equipment and interference generators via shielded coaxial cable). There shall be adequate shielding around the EUT (and possibly the companion device) to prevent unintended RF coupling.

Clause 5 provides guidance on measurement instrumentation and signal generators for performing the tests. Clause 9 summarizes the information that should be provided in the test report.

2. References

The following references shall form a part of this standard to the extent that they are referenced herein. When ANSI and IEEE Standards are superseded by a revision, the version specified in this document shall apply.

ANSI C63.2-1996, American National Standard for Electromagnetic Noise and Field Strength Instrumentation, 10 kHz to 40 GHz—Specifications.²

ANSI C63.4-1992, American National Standard for Methods of Measurement of Radio-Noise Emissions from Low-Voltage Electrical and Electronic Equipment in the Range of 9 kHz to 40 GHz.

ANSI C63.5-1988, American National Standard for Calibration of Antennas Used for Radiated Emission Measurements in Electromagnetic Interference (EMI) Control.

¹“Channel” is used here to denote a time/spectrum window.

²ANSI C63 publications are available from the Institute of Electrical and Electronics Engineers, 445 Hoes Lane, P.O. Box 1331, Piscataway, NJ 08855-1331, USA, or from the Sales Department, American National Standards Institute, 11 West 42nd St., New York, NY 10036, USA.

ANSI C63.6-1988, American National Standard Guide for the Computation of Errors in Open-Area Test Site Measurements.

ANSI C63.7-1992, American National Standard for Construction of Open-Area Test Sites for Performing Radiated Emission Measurements.

ANSI C63.14-1992, American National Standard Dictionary for Technologies of Electromagnetic Compatibility (EMC), Electromagnetic Pulse (EMP), and Electrostatic Discharge (ESD) (*Dictionary of EMC/EMP/ESD Terms and Definitions*).

IEEE Std 100-1996, The IEEE Standard Dictionary of Electrical and Electronics Terms.³

IEEE Std 149-1979 (Reaff 1990), IEEE Standard Test Procedures for Antennas.

IEEE Std 291-1991, IEEE Standard Methods for Measuring Electromagnetic Field Strength of Sinusoidal Continuous Waves, 30 Hz to 30 GHz.

47 CFR 15, Subpart D—Unlicensed Personal Communications Services Devices.⁴

3. Definitions, acronyms and abbreviations, and symbols

3.1 Definitions

The definitions in IEEE Std 100-1996 and ANSI C63.14-1992, unless otherwise noted below, apply throughout this document. Definitions in particular product standards or in applicable regulations take precedence. Sources of definitions (if applicable) are enclosed in brackets following the definition.

3.1.1 absorber-lined open-area test site: An open-area test site with a radio frequency (RF) absorber-covered ground plane, to reduce reflections to an acceptable level.

NOTE—According to the requirements of this standard, an acceptable level is 10 dB below the direct-path signal strength.

3.1.2 anechoic enclosure: An enclosure whose internal walls have low reflection characteristics. [ANSI C63.14-1992]

3.1.3 asynchronous devices: Devices that transmit radio frequency (RF) energy at irregular time intervals, as typified by local area network data systems. [47 CFR 15, Subpart D, 15.303(a)]

3.1.4 asynchronous reaction time: The time interval beginning when a device senses a clear observation window and ending when it begins transmission. [ANSI C63, Subcommittee 7]

3.1.5 asynchronous sub-band: The spectrum allocated for asynchronous transmission. [Extraction from 47 CFR 15, Subpart D, 15.303(i)]

3.1.6 asynchronous transmission burst: A series of transmissions from one or more transmitters acting cooperatively. [47 CFR 15, Subpart D, 15.323(f)]

3.1.7 band: Range of frequency between two defined limits. [IEEE Std 100-1996]

³IEEE publications are available from the Institute of Electrical and Electronics Engineers, 445 Hoes Lane, P.O. Box 1331, Piscataway, NJ 08855-1331, USA.

⁴CFR publications are available from the Superintendent of Documents, U.S. Government Printing Office, P.O. Box 37082, Washington, DC 20013-7082, USA.

3.1.8 bandwidth (BW): The range of frequencies within which performance, with respect to some characteristic, falls within specific limits. [IEEE Std 100-1996]

3.1.9 Boltzmann's constant (k): The number k that relates the average energy of a molecule to the absolute temperature of the environment. k is approximately 1.38×10^{-23} joules/kelvin. [IEEE Std 100-1996]

3.1.10 center half (of sub-band): A range of frequencies centered in the sub-band and having a span equal to 1/2 of the width of the sub-band. If F_a is the lower-frequency edge of the sub-band and F_b is the upper-frequency edge of the sub-band, then the center half of the sub-band is equal to $(F_a + F_b)/2 \pm (F_a - F_b)/4$. [ANSI C63, Subcommittee 7]

3.1.11 conducted emission and monitoring tests: Tests performed with radio frequency (RF) signal sources (to test monitoring thresholds) and instrumentation (to measure emissions) connected directly to the antenna port on the equipment under test (EUT) transceiver, via shielded coaxial cable and passive combiner/splitter networks. *See also:* **radiated emission and monitoring tests.**

3.1.12 coordinatable PCS device: Personal communications services (PCS) devices whose geographical area of operation is sufficiently controlled either by necessity of operation with a fixed infrastructure or by disabling mechanisms to allow adequate coordination of their locations relative to incumbent fixed microwave facilities. [47 CFR 15, Subpart D, 15.303(b)]

3.1.13 digital modulation: The process by which the characteristics of a carrier wave are varied among a set of predetermined discrete values in accordance with a digital modulating function. [ANSI C63, Subcommittee 7]

3.1.14 emission bandwidth (B): The width, in Hz, of the signal between two points, one below the carrier center frequency and one above the carrier center frequency, that are 26 dB down relative to the maximum level of the modulated carrier. It is based on the use of measurement instrumentation employing a peak detector function with an instrument resolution bandwidth approximately equal to 1% of the emission bandwidth of the device under measurement. [Extraction from 47 CFR 15, Subpart D, 15.303(c)]

3.1.15 equipment under test (EUT): The device, equipment, subsystem, or system that is to be tested or that is under test. [ANSI C63.14-1992]

3.1.16 frame jitter: Time-related, abrupt, spurious variations in the duration of the frame interval. [47 CFR 15, Subpart D, 15.321(e)]

3.1.17 frame period: A set of consecutive time slots in which the position of each time slot can be identified by reference to a synchronizing source. [47 CFR 15, Subpart D, 15.321(e)]

3.1.18 intentional radiator: A device that intentionally generates and emits radio frequency (RF) energy by radiation or induction. [47 CFR 15, Subpart D, 15.3(o)]

3.1.19 isochronous devices: Devices that transmit at a regular interval, typified by time-division voice systems. [47 CFR 15, Subpart D, 15.303(d)]

3.1.20 isochronous reaction time: The duration of radio frequency (RF) power during monitoring that shall be detected by the device that determines that the monitored time and spectrum window is occupied. [ANSI C63, Subcommittee 7]

3.1.21 isochronous sub-band: The spectrum allocated for isochronous transmission. [47 CFR 15, Subpart D, 15.303(i)]

3.1.22 least interfered channel (LIC): An interference avoidance mechanism that extends the listen before transmit (LBT) mechanism to monitor all potential channels, determining the least interfered channel, before

transmitting on that channel. Under 47 CFR 15, Subpart D, 15.323, this mode of operation is limited to those devices with 40 or more channels. *See also: listen before transmit.*

3.1.23 listen before transmit (LBT): An interference avoidance mechanism that mandates monitoring of a selected channel to determine availability before transmission.

3.1.24 noncoordinatable PCS device: A personal communications services (PCS) device that is capable of randomly roaming and operating in geographic areas containing incumbent microwave facilities, such that operation of the PCS device will potentially cause harmful interference to the incumbent microwave facilities. [47 CFR 15, Subpart D, 15.303(e)]

3.1.25 open-area test site (OATS): A site for electromagnetic measurements that is open, flat terrain at a distance far enough away from buildings, electric lines, fences, trees, underground cables, pipelines, and other potential reflective objects that the effects due to such are negligible. See ANSI C63.7-1992 for guidance on the construction of open-area test sites. [ANSI C63.14-1992]

3.1.26 operational failure: The inability of an equipment under test (EUT) to perform a function that is required as a response to system conditions or to a manually or automatically initiated command. [ANSI C63, Subcommittee 7]

3.1.27 peak transmit power: The peak power output as measured over an interval of time equal to the transmission-burst duration of the device under all conditions of modulation. [47 CFR 15, Subpart D, 15.303(f)]

3.1.28 power spectral density: The average pulse energy in a 3 kHz bandwidth divided by the pulse duration (see Annex C).

3.1.29 radiated emission and monitoring tests: Tests performed with radio frequency (RF) signal sources (to test monitoring thresholds) and instrumentation (to measure emissions) connected to test antennas. *See also: conducted emission and monitoring tests.*

3.1.30 semianechoic room/chamber: A test enclosure featuring a reflective ground plane at the floor and RF absorber-lined internal walls and ceiling that produce sufficiently low reflections in the frequency range of interest. As an electromagnetic compatibility (EMC) test facility, the semianechoic room is equivalent to the open-area test site and shall meet the test site attenuation requirements of ANSI C63.4-1992. *See also: open-area test site.*

3.1.31 shielded enclosure: A mesh or sheet metallic housing designed expressly for the purpose of separating electromagnetically the internal and the external environment. [ANSI C63.14-1992]

3.1.32 shielded room: *See: shielded enclosure.* [ANSI C63, Subcommittee 7]

3.1.33 spectrum window: An amount of spectrum equal to the intended emission bandwidth in which operation is desired. [47 CFR 15, Subpart D, 15.303(h)]

3.1.34 sub-band: The spectrum allocated for isochronous or asynchronous transmission. [47 CFR 15, Subpart D, 15.303(i)]

3.1.35 TEM cell: A measuring device that is designed to utilize the transverse electromagnetic mode (TEM) over the frequency range of interest. Common examples are the two-port TEM cell (also known as the Crawford Cell) and the wideband TEM cell. [ANSI C63.4-1992]

3.1.36 thermal noise power: The noise power (in W) defined by the formula $N = kTB$, where N is the noise power, in W, k is Boltzmann's constant, T is the absolute temperature, in degrees kelvin (e.g., 295 °K), and B is the emission bandwidth of the device, in Hz. [47 CFR 15, Subpart D, 15.303(j)]

3.1.37 time window: An interval of time in which transmission is desired. [47 CFR 15, Subpart D, 15.303(k)]

3.1.38 transmit power: The total energy transmitted over a time interval of no more than $30/B$ (where B is the emission bandwidth of the signal), divided by the interval duration. [ANSI C63, Subcommittee 7]

3.1.39 unlicensed personal communications service (UPCS) device: Intentional radiators operating in the frequency band specified by the applicable regulating agency that provide a wide array of mobile and ancillary fixed communication services to individuals and businesses. [Modification of 47 CFR 15, Subpart D, 15.303(g)]

3.1.40 wavelength (λ): Of a monochromatic wave, the distance between two points of corresponding phase of two consecutive cycles in the direction of the wave normal. [IEEE Std 100-1996]

3.1.41 wideband (WB) TEM cell: A transverse electromagnetic mode (TEM) cell that has been altered to extend the usable frequency range. Often, this is achieved by replacing one port of a two-port TEM cell with a nontapered, wideband load. [ANSI C63.4-1992]

3.2 Acronyms and abbreviations

ANSI	American National Standards Institute
BW	bandwidth
CAT	computed average transient
CW	continuous wave
dB	decibel
dB _A	decibels referenced to 1 ampere
dB _c	decibels referenced to the carrier
dB _i	decibels referenced to isotropic (antenna gain)
dB _m	decibels referenced to 1 milliwatt
dB μ V	decibels referenced to 1 microvolt
dB(μ V/m)	decibels referenced to 1 microvolt per meter
EIRP	effective isotropically radiated power
EMC	electromagnetic compatibility
EMP	electromagnetic pulse
ESD	electrostatic discharge
EUT	equipment under test
FCC	Federal Communications Commission
FDMA	frequency-division multiple access
FFT	Fast Fourier Transform
GHz	gigahertz
Hz	hertz
IEEE	Institute of Electrical and Electronics Engineers
IF	intermediate frequency
kHz	kilohertz
LAN	local area network
LBT	listen before transmit
LIC	least interfered channel
MC	multicarrier
MHz	megahertz
ms	millisecond
μ s	microsecond
mW	milliwatt
OATS	open-area test site
P	transmit power

PCS	personal communications services
ppm	parts per million
PSD	power spectral density
RBW	resolution bandwidth
RF	radio frequency
rms	root mean square
Rx	receiver
TDMA	time-division multiple access
TEM	transverse electromagnetic
Tx	transmitter
UPCS	unlicensed personal communications services
VSWR	voltage standing wave ratio
W	watt
WB-TEM	wideband transverse electromagnetic cell

3.3 Symbols

<i>B</i>	emission bandwidth, in Hz
<i>k</i>	Boltzmann's constant, in joules/kelvin
<i>M</i>	monitoring threshold
<i>T</i>	temperature, in degrees kelvin

4. Radiated and conducted test methodology

To perform the RF emission tests in Clause 6 and the monitoring and access tests in Clauses 7 and 8, it is necessary to have controlled RF paths between the EUT and the measurement instrumentation, and between the EUT and the interference generators. If the EUT requires a companion device to operate, there also shall be a controlled RF path between the EUT and its companion device.

These controlled RF paths may be realized either as “radiated” (through space) or “conducted” (over coaxial cable) paths. In the radiated case, the tests shall be performed in a facility with controlled RF propagation characteristics, so that the path loss can be controlled by varying separation between transceiver and monitoring/source antennas. In the conducted case, the tests can be performed anywhere that there is adequate shielding to prevent external interference from affecting the test results. Signals can be combined and distributed using passive networks (e.g., hybrids, Butler matrices,⁵ and directional couplers). Path loss can be controlled with RF attenuators. Conducted tests are preferred to radiated tests, and should be used if the EUT antenna can be detached for testing purposes.

This clause provides guidance on the implementation of the conducted and radiated measurements of transmit power and monitoring threshold. Supporting derivations are given in Annex D.

4.1 Test facilities and equipment

Tests should be performed at the manufacturer's recommended normal operating temperature and voltage.⁶ Unless stated otherwise, the requirements of ANSI C63.4-1992 apply to the test facilities, including site design, dimensions, and validation. Additional site validation requirements above 1 GHz currently are under development. Portions of this standard place requirements on the test facilities in addition to the general requirements of ANSI C63.4-1992.

When shielded facilities (e.g., shielded rooms, semianechoic chambers, or anechoic chambers) are used for operational compatibility testing, the shielding effectiveness of the room shall be such as to ensure compli-

⁵A Butler matrix is a network of 3 dB hybrids that provides a passive combining/splitting function for coupling multiple RF inputs to multiple RF outputs.

⁶Where this is not specified, conditions of 20 °C and 115 V ac (or fresh battery pack) may be used.

ance with electromagnetic emission limits for the environment outside of the room and to reduce the ambi-ents penetrating into the room to levels at least 10 dB below the weakest measured signal. When the free-space test environment is simulated, the reflections from the facility confines, as well as the reflections from any extraneous objects at the test site, shall be reduced to levels at least 10 dB below the direct (free-space) signal.

The diagram in Figure 1 lists the types of test facilities for measurements specified in this standard.

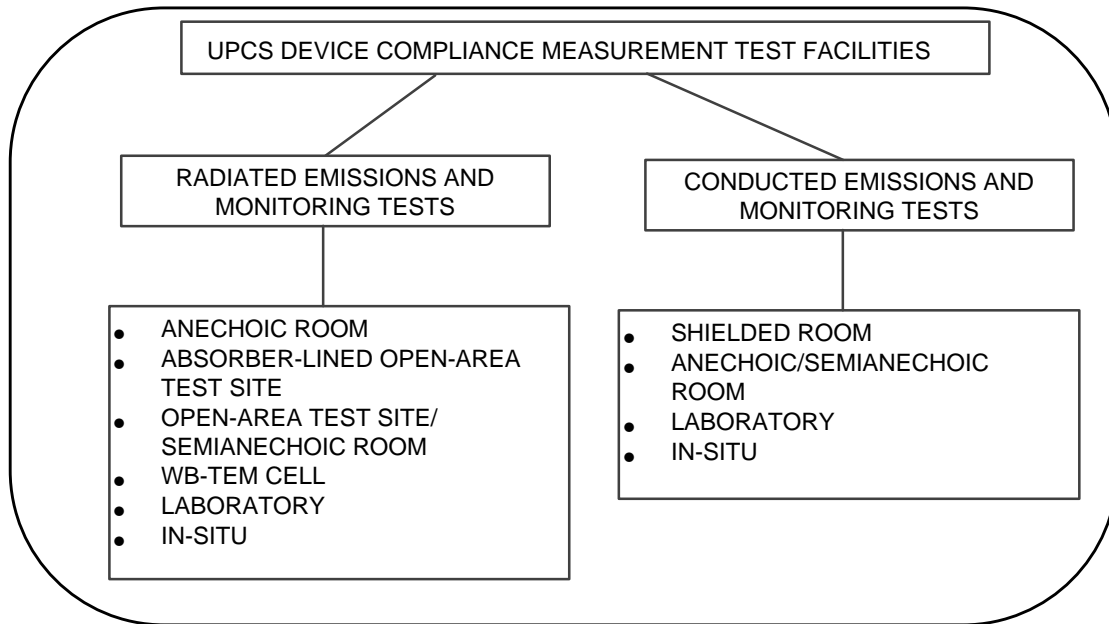

Figure 1—Recommended test facilities

The choice of the test facility is determined by the regulatory agency.

4.2 Test configurations and setup

Clause 6 provides detailed tests of parameters related to RF emissions, such as peak transmit power, emission bandwidth, and power spectral density. These tests are similar to emission tests performed on most non-UPCS devices. Clauses 7 and 8 provide tests that verify compliance with the monitoring and access requirements that are unique to UPCS devices. These tests require observation of the EUT’s behavior in the presence of controlled interference of a specific frequency, power level, and modulation format. The monitoring and access tests have implications on the conducted and radiated test setups.

The monitoring antenna refers to the EUT antenna used to monitor the RF signal on the channel prior to transmission. In many cases, the monitoring antenna will be the same as the transmitting antenna. If it is not, then the monitoring and access tests are further complicated by the need to ensure that the monitoring antenna provides “coverage” that is at least equivalent to that which would be provided by the transmit antenna.

This standard identifies six test configurations. Each configuration is discussed in a separate subclause, as shown in the following table.

Transmit/monitoring antenna comparison and placement	Subclause	
	Conducted measurement based test (preferred)	Radiated measurement based test
Single, or identical collocated*	4.4	4.7
Different collocated	4.5	4.8
Arbitrarily placed	4.6	4.9

* Antennas of the same type with a separation distance of 1 m or less, mounted on or within the same physical housing for the purpose of providing diversity against multipath fading, are considered to be "identical collocated."

The measurement type (i.e., conducted or radiated) can be selected independently of type and placement by the product manufacturer and can be specified in the compliance report. Conducted measurements generally are required for systems with detachable antennas.

Compliance measurements utilize standard EMC and antenna techniques for conducted power, radiated field, and EIRP measurements. The conducted test setup is based on power measurements at the EUT transmit, receive, and monitoring antenna terminals. The associated compliance limits for the UPCS products depend on the transmit antenna gain, G_A . The value of G_A is declared by the manufacturer.

Since the transmitter and receiver radiated-power parameters can be expressed in several different but equivalent ways, a number of alternative compliance test procedures can be used for radiated measurements. The general radiated test setup is based on free-space environment measurements, as shown in Figure 2, where D is the largest dimension of the EUT (see Figure 8 for the general conducted test setup). The free-space test site is defined such that the reflections from any ground planes and other reflecting objects are at least 10 dB below the line-of-sight signal. The reference antenna is used to measure the EUT radiating power and to establish the monitoring threshold fields at the transmit and monitoring antennas. The associated compliance limits are based on the EIRP. The antenna gain and the EIRP evaluations should be performed as recommended by IEEE Std 149-1979.

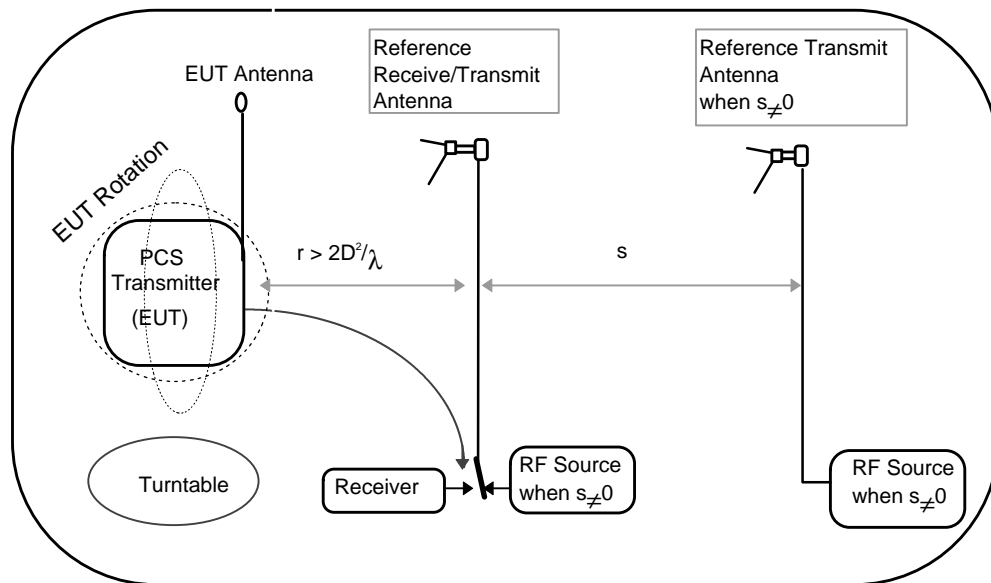

Figure 2—Radiated measurements in free-space environment

Equivalent radiated tests can be performed in facilities that do not provide for a free-space environment and/or measure radiated power (e.g., WB-TEM, etc.). Instead of using the reference antenna, the necessary power levels are generated and/or measured by the test facility itself. If alternative measurements are used, the test results shall be correlated with those obtained using antenna measurements in a free-space environment.

4.3 Transmitted power and monitoring threshold limits

The EUT transmit power limit, at the antenna terminals, is

$$P_{EUT} \leq \begin{cases} P_{\max} - (G_A - g), & \text{when } G_A > g \\ P_{\max}, & \text{when } G_A \leq g \end{cases} \quad (1)$$

where

- P_{\max} equals $5 \log B - 10$ dBm, or $10^{-4} \sqrt{B}$, in W.
- B is the emission bandwidth, in Hz.
- G_A is the EUT transmit antenna maximum gain (declared by the manufacturer), in dBi.
- g is the allowable excess gain over that of an isotropic antenna without a transmit power reduction.⁷

The maximum monitoring threshold power at the monitoring antenna terminals is

$$T_M = T_{Mi} + P_{\max} - P_{EUT} \text{ (dBm)} \quad (2)$$

where

- T_{Mi} equals $-174 + 10 \log B + M$ dBm.
- M is the amount by which the threshold exceeds thermal noise for a device transmitting the maximum allowed power, in dB.

When conducted tests are performed, the limits shown in Equations (1) and (2) apply directly. For radiated tests, those limits shall be translated to the equivalent limits on EIRP and monitoring threshold field strength, respectively. EIRP limits⁸ corresponding to Equation (1) are

$$EIRP_{EUT} \leq \begin{cases} P_{\max} + g, & G_A > g \\ P_{\max} + G_A, & G_A \leq g \end{cases} \quad (3)$$

To test for monitoring threshold compliance using radiated techniques, a reference antenna is used to generate the required field strength at the monitoring antenna. The transmit power that shall be applied to the reference antenna terminals to induce a power level can be expressed in terms of the EIRP as

$$P_{Tref} = T_{Mi} + P_{\max} - EIRP_{EUT} - 20 \log (\lambda/4\pi r) - G_{REF} \quad (4)$$

or, in terms of the maximum measured field strength at a distance, r , from the EUT, as

$$P_{Tref} = T_{Mi} + P_{\max} - E_{EUT\max} + 20 \log_{10} f - G_{REF} - 42.8 \quad (5)$$

⁷47 CFR 15, Subpart D, 15.319(e), specifies that $g = 3$ dBi.

⁸Because the EIRP limit is independent of G_A for $G_A > 3$ dBi, and most practical radiating devices will not have a gain sufficiently below 3 dBi for the difference of 3 dBi - G_A to be accurately measurable, there may be a gain-independent EIRP limit in the future.

where

- G_{REF} is the gain of the reference antenna in the direction of the EUT, in dBi.
- f is the signal frequency, in Hz.
- λ is the wavelength, in meters.
- r is the distance from the reference antenna to the EUT monitoring antenna.

In Equation (5), it is assumed that r is the same for measurement of the radiated field strength and the monitoring threshold.

4.4 Conducted measurements of products with collocated transmitting and monitoring antennas of the same type

The EUT antenna shall be disconnected and the power, P_{EUT} , at its terminals shall be measured during EUT transmission, as specified in Clause 6. The monitoring threshold(s) shall be measured using the procedures in Clause 7. The EUT fails if it does not meet the criteria of Equations (1) and (2).

4.5 Conducted measurements of products with collocated transmitting and monitoring antennas of different types

When the monitoring antenna is different from the transmitting antenna, it shall be verified that the monitoring antenna provides coverage equivalent to that of the transmitting antenna. This means that the monitoring system shall cause deference to any transmission of sufficient strength to induce a power level in the EUT transmit antenna that exceeds the threshold for the EUT, as measured at the transmitting antenna input.

The transmit power compliance test of Clause 6 shall be performed as stated in 4.4. The maximum threshold, T_M , shall be calculated using Equation (2), and it shall be verified that the EUT transmits when power sufficiently less than T_M is applied to the monitoring antenna terminals and defers when power equal to or greater than T_M is applied to the terminals.

The equivalent coverage test for the transmitting and monitoring antennas is performed as follows:

- a) Set up the reference antenna with vertical polarization, and with its major lobe facing the EUT, at a distance, r (meeting the far-field conditions), from the EUT antennas.
- b) Illuminate the EUT with the reference antenna from a number of positions covering the surface of a sphere around the EUT with a radius of r . This can be done by positioning the EUT in three orthogonal planes and rotating it over a range of 0–360° in each plane. The rotation may be discrete or continuous.
- c) While rotating the EUT, apply power to the terminals of the reference antenna and adjust it to the level P_{Tref} so as to maintain a received power of T_M at the EUT transmit antenna terminals for any orientation.
- d) Repeat the test with horizontal polarization for the reference antenna.

The EUT shall defer at each position for one or the other of the two orthogonal polarizations of the reference antenna. Otherwise, the EUT fails the equivalent coverage test.

4.6 Conducted measurements of products with arbitrarily placed transmitting and monitoring antennas

The transmit power compliance test of Clause 6 shall be performed as stated in 4.4. The maximum threshold, T_M , shall be calculated using Equation (2), and it shall be verified that the EUT transmits when power sufficiently less than T_M is applied to the monitoring antenna terminals and defers when power equal to or greater than T_M is applied to the terminals.

The equivalent coverage test for the transmitting and monitoring antennas is performed as follows:

- a) Set up the reference antenna with vertical polarization, and with its major lobe facing the EUT, at a distance, r (meeting the far-field conditions), from the EUT transmit antenna in the direction of the EUT's maximum radiation.
- b) Apply power to the reference antenna terminals and adjust it to the level P_{Tref} so as to obtain power, T_M , at the EUT transmit antenna terminals.
- c) Move the reference antenna (without changing its orientation) in the direction of the EUT's maximum radiation to a distance, $r + s$, from the monitoring antenna (where s is the maximum possible distance between the transmit and monitoring antennas), as specified by the EUT manufacturer.
- d) Align the EUT monitoring antenna such that the direction of its minimum sensitivity faces the reference antenna.
- e) Apply power, P_{Tref} to the reference antenna and illuminate the EUT monitoring antenna.

The EUT shall defer for one or the other of two orthogonal reference antenna polarizations. Otherwise, the EUT fails the equivalent coverage test.

4.7 Radiated measurements of products with collocated transmitting and monitoring antennas of the same type

The EUT and reference antenna shall be set up, with the major lobe of the reference antenna facing the EUT, in the far field with a separation of r . The EUT transmission shall be initiated, and the direction of the EUT's maximum radiation shall be found. The EUT EIRP shall be measured. $EIRP_{EUT}$ (dBm) can be calculated from the measured radiated-field intensity in the direction of maximum radiation, E_{EUTmax} , using

$$EIRP_{EUT} = E_{EUTmax} + 20 \log r - 104.8 \quad (6)$$

where E_{EUTmax} is in dB μ V/m.

Using the nominal value of the EUT gain, G_A , declared by the manufacturer, the limit on $EIRP_{EUT}$ shall be calculated using Equation (3). If $EIRP_{EUT}$ exceeds the limit, the EUT fails the test.

Compliance with the monitoring threshold limits is verified as follows:

- a) Using Equations (4) or (5), calculate the power, P_{ref} that shall be applied to the reference antenna terminals to establish the monitoring threshold field level (denoted by E_M in Annex D) at the EUT transmit antenna (this would induce a power level of T_M at the terminals of a lossless antenna with a gain of G_A).
- b) Apply power first smaller than, then equal to, P_{Tref} to the reference antenna terminals. Illuminate the EUT in the direction of maximum radiation, while continuously attempting to initiate the EUT transmission. Verify that there is at least one position of the EUT in which it will transmit when sufficiently low power is applied to the reference antenna terminals.
- c) When the power level applied to the reference antenna is equal to and larger than P_{Tref} the EUT shall defer for one or the other of two orthogonal polarizations of the reference antenna (e.g., vertical and horizontal). Otherwise, the EUT fails the test.
- d) As the EUT is rotated, monitor the power received by the reference antenna when the EUT transmits, and adjust the threshold accordingly.

4.8 Radiated measurements of products with collocated transmitting and monitoring antennas of different types

The EUT and reference antenna shall be set up, with the major lobe of the reference antenna facing the EUT, in the far field with a separation of r . The transmission test shall be performed as described in 4.7, and it shall be verified that $EIRP_{EUT}$ meets the limits.

Compliance with the monitoring threshold limits is verified using the same procedure as described in 4.7.

4.9 Radiated measurements of products with arbitrarily placed transmitting and monitoring antennas

The reference antenna shall be set up, with its major lobe facing the EUT, in the far field with a separation of r . The transmission test shall be performed as described in 4.7, and it shall be verified that $EIRP_{EUT}$ meets the limits.

The equivalent coverage test for the transmitting and monitoring antennas is performed as follows:

- a) Calculate, as described in 4.7, the power, P_{Tref} , that shall be applied to the reference antenna to establish the monitoring threshold field at the EUT transmit antenna.
- b) Move the reference antenna (without changing its orientation) in the direction of the EUT maximum radiation at a distance, $r + s$, from the monitoring antenna (where s is the maximum possible separation distance between the transmit and monitoring antennas), as specified by the EUT manufacturer.
- c) Apply power first smaller than, then equal and larger than, P_{Tref} to the reference antenna terminals and illuminate the EUT monitoring antenna. Investigate a number of the EUT monitoring antenna placements and positions on the surface of a sphere around the EUT monitoring antenna, as described in 4.7, while attempting to initiate transmission. There should exist a sufficiently low reference antenna power level (smaller than P_{Tref}) such that the EUT is able to transmit, at least at one EUT antenna position.
- d) When the power level applied to the reference antenna is equal or larger than P_{Tref} , the EUT shall defer at all positions of the monitoring antenna, for either horizontal or vertical reference antenna polarizations. Otherwise, the EUT fails the test.

5. Measurement instrumentation

This clause provides information on measurement instrumentation.

Alternative test methods using different equipment may be employed. Some items described here are alternative choices.

5.1 Antennas

Calibrated, linearly polarized antennas should be used as specified in ANSI C63.2-1996. These include double-ridged guide horns, rectangular waveguide horns, pyramidal horns, optimum gain horns, and standard gain horns. The beam or major lobe of the pattern of any antenna used shall be large enough to encompass the EUT when located at the measuring distance. The aperture dimensions of these horn antennas shall be small enough that the measurement distance, in meters, is equal to or greater than the Rayleigh Distance (i.e., $R_m = D^2/2\lambda$, where D is the largest dimension of the aperture, in meters, of the antenna, and λ is the free-space wavelength, in meters, at the frequency of measurement). In case of dispute, measurements made with the standard gain horn antenna shall take precedence.

5.2 Digital storage oscilloscope

A digital storage oscilloscope shall provide the following functionality:

- Two channels
- Pre/post trigger delay
- Delayed sweep
- Cursor with readout of amplitude and time values

A digital storage oscilloscope shall meet the following minimum performance requirements:

Bandwidth—repetitive:	dc to 50 MHz
Bandwidth—single shot:	1 MHz
Time accuracy:	± 0.01%
Time interval resolution—repetitive:	± 1 ns
Digitizing rate:	20 MSa/s
Sweep speed:	1 s/div to 10 ns/div
Vertical accuracy:	± 3%
Vertical resolution:	8 bits
Vertical sensitivity (1:1 probe):	5 mV/div to 5 V/div
Input impedance:	1 MΩ
Input coupling:	ac, dc

5.3 Frequency counter

A frequency counter shall provide the following functionality:

- Frequency and period measurements
- Averaging of measurement with statistics, including standard deviation
- External measurement gating for measurement of noncontinuous (burst) signals

A frequency counter shall meet the following minimum performance requirements:

Frequency range:	Usable over the applicable radio frequency range
Frequency resolution:	9 digits in 1 s of measurement time
Frequency accuracy:	0.2 ppm
Power range and sensitivity:	−25 to +28 dBm

External attenuation may be used to meet the high-power end of the range and can be considered as part of the equipment.

5.4 Low-noise amplifier

A low-noise amplifier shall meet the following minimum performance requirements:

Frequency range:	Usable over the applicable radio frequency range
Gain:	20 dB
Noise figure:	4 dB
Power out 1 dB gain compression:	+10 dBm

5.5 Modulation analyzer or frequency and time-interval analyzer

A modulation analyzer or frequency and time-interval analyzer shall provide the following functionality:

- Continuous measurement for frequency, period, and time intervals
- Presentation of measured values vs. time and presentation of histogram results
- Adjustable sampling rate and sample size
- Calculation of statistics including mean, minimum, maximum, and standard deviation
- RF envelope detection with detected output

A modulation analyzer or frequency and time-interval analyzer shall meet the following minimum performance requirements:

Frequency range:	Tunable over the applicable frequency range
Frequency resolution:	Selectable to 1 ppm
Time interval resolution:	Symbol rate/10
RF burst width:	50 μ s to continuous
Dynamic range:	-10 dBm to + 20 dBm
Input impedance:	50 Ω nominal
Sample rate:	Up to 1 MHz

5.6 Alternative instrumentation

While the tests described in this standard are based on general-purpose instrumentation, tests using alternative, more specialized instrumentation can, in some cases, be performed more quickly with equally valid results. For some EUT (e.g., those operating in conformance with an industry standard air interface), instruments may be available that are specifically designed to test equipment using a particular type of modulation, frequency channelization, frame structure, etc. Those instruments may be capable of automatically performing some of the tests specified in Clause 6 (e.g., emission bandwidth and power spectral density). Such instruments can be used instead of general-purpose instruments (spectrum analyzers, signal analyzers, etc.) to perform the tests of which they are capable, provided that the manufacturer notes that this is permissible on the grant application and provides the necessary data regarding the test instrument.

5.7 Square-notch interference generator

A square-notch interference generator shall provide the following functionality:

- Flat pseudo-random noise output
- Multiple notches in the noise output, adjustable in depth and width
- Multiple continuous wave (CW) tones that can be combined with the noise output

An interference generator shall meet the following minimum performance requirements:

Bandwidth:	Adequate to apply interference over the range of EUT operating frequencies
Frequency resolution:	1 kHz
Output accuracy:	± 2 dB over 1.25 MHz
Power spectral density range:	-150 dBm/Hz to -100 dBm/Hz
External attenuation may be used to meet the low-power end of the range and can be considered part of the equipment.	
Amplitude resolution:	1 dB

5.8 Multicarrier interference generator

A multicarrier interference generator shall be capable of generating CW signals on any selected combination of EUT carrier frequencies. For some EUT, the multicarrier generator is a practical alternative to the square-

notch generator for applying out-of-operating-region interference to the EUT (see 7.2.4). Its exact specifications depend on the EUT, but shall meet or exceed the following:

Independently-switchable (on/off) EUT carriers combined in a single 50 Ω RF output	
Power output per carrier:	≥ -35 dBm
Frequency tolerance:	$\leq 10\%$ of EUT center frequency separation
Adjacent channel interference:	≤ -30 dBc in EUT receiver noise bandwidth

5.9 Power meter

A power meter shall provide the following functionality:

- Average power measurements
- True rms detection for both sinusoidal and nonsinusoidal signals
- Absolute power in linear (W) and logarithmic (dBm) units
- Relative (offset) power in dB and percentage units
- Automatic calibration and zeroing
- Averaging of multiple readings

A power meter shall meet the following minimum performance requirements:

Frequency range:	Covers applicable range of radio frequencies
Power range:	-10 dBm (0.1 mW) to $+30$ dBm (1 W)
Absolute and relative power accuracy:	± 0.2 dB (5%)
	Excludes sensor and source mismatch (VSWR) errors, zeroing errors (significant at bottom end of sensor range), and power linearity errors (significant at top end of sensor range).
Power measurement resolution:	≤ 0.1 dB
Sensor VSWR:	1.15:1

5.10 Pulse/arbitrary waveform generator

A pulse/arbitrary waveform generator shall meet the following minimum performance requirements:

Arbitrary waveform length:	Up to 16k points
Arbitrary amplitude resolution:	12 bits
Arbitrary sample rate:	40 MSa/s
Arbitrary memory:	Four 16k waveforms
Timing accuracy:	100 ppm
Rise/fall time:	200 ns
Output amplitude:	Up to 10 V peak-to-peak
Output impedance:	50 Ω
Trigger:	Internal and external

5.11 Signal generator

A signal generator shall meet the following minimum performance requirements:

Output frequency range:	Tunable over applicable range of radio frequencies
Frequency accuracy:	± 10 ppm
Frequency resolution:	1 kHz
Output range:	-50 dBm to -10 dBm, and off
Output accuracy:	± 1 dB for above amplitude range and frequencies < 1 GHz
Output resolution:	0.1 dB

5.12 Spectrum analyzer

A spectrum analyzer shall provide the following functionality:

- General purpose frequency domain measurements
- Time domain (zero span) measurements with true average power determination

A spectrum analyzer shall meet the following minimum performance requirements:

Frequency range:	Tunable over the applicable radio frequency range. To test devices under 47 CFR 15, Subpart D, testing up to the tenth harmonic is required.
Frequency setting resolution:	1 kHz
Frequency accuracy:	± 0.2 ppm
Displayed dynamic range:	70 dB
Display log scale fidelity:	± 1 dB over the above displayed dynamic range
Amplitude measurement range for signals from 10 MHz to 2.5 GHz:	
Power measured in 30 kHz RBW:	-50 to +30 dBm

External attenuation may be used to meet the high power end of the range and can be considered as part of the equipment.

Absolute amplitude accuracy in the transmit and receive bands:

For frequency domain measurements with RBW of 300 Hz to 100 kHz:	± 1.5 dB over the range of -40 dBm to +26 dBm
Relative flatness:	± 1.5 dB over frequency range 10 MHz to 2.5 GHz
RBW filter:	Synchronously tuned or Gaussian (at least 3 poles) with 3 dB bandwidth selections of 3 MHz, 1 MHz, 300 kHz, 100 kHz, 30 kHz, 10 kHz, 3 kHz, 1 kHz, and 300 Hz. For asynchronous devices with emission BW > 2.5 MHz, a wider RBW is required for certain measurements.
Post detection video filters:	Selectable in decade steps from 100 Hz to at least 3 MHz
Detection modes:	Selectable to be either peak or sample
RF input impedance:	Nominal 50 Ω
Time domain sweep times:	Selectable from 100 μ s to 100 ms
External delayed sweep trigger:	Selectable from 5 μ s to 40 ms

5.13 Complex waveform analyzer

A complex waveform analyzer shall provide the following functionality:

- FFT-based spectrum measurements, with independent selection of RBW and span.
- Simultaneous measurement of frequency domain and time domain data. The time data will have a 3 dB bandwidth greater than the measurement bandwidth and will be used to compute both the power spectrum (via an FFT) and the power envelope. When time corrections are specified, the analyzer will meet the amplitude accuracy specification for time domain data.
- Frequency domain measurements: peak power and integrated power over a frequency band.
- Time domain measurements: peak power and true average power over a time interval.

A complex waveform analyzer shall meet the following minimum performance requirements:

Frequency range:	Tunable over the applicable radio frequency range
Frequency setting resolution:	1 kHz
Frequency accuracy:	± 0.2 ppm
Frequency span (measurement BW):	> emission BW of EUT, but not < 1.25 MHz
Dynamic range:	70 dBc
Amplitude input range for signals from 10 MHz to 2.5 GHz:	
Peak envelope power:	-30 to +40 dBm
Attenuator step size:	≤ 5 dB external attenuation may be used to meet the high-power end of the range and can be considered as part of the equipment.
Input noise density:	-100 dB/Hz (referenced to full-scale input)
Absolute amplitude accuracy:	
Frequency domain:	± 1.5 dB over applicable radio frequency range
Time domain:	± 1.5 dB for a full-scale sine wave placed anywhere within the frequency span
RBW filter (FFT window function):	Uniform (none), Gaussian. For Gaussian window, noise BW ≤ 3 kHz for frequency spans ≤ 2.5 MHz.
Detector mode:	Sample
RF input impedance:	Nominal 50 Ω
Spectral averaging:	RMS
Triggering:	RF envelope with trigger holdoff
Trigger delay:	0-10 ms

5.14 Antenna calibration

All antennas shall be individually calibrated to show traceability to the National Institute of Standards and Technology (NIST) or to an equivalent standards reference organization. Antenna factors shall be rechecked at least once a year, either by recalibration techniques or by checking against reference antennas or known signal sources. Spot-checking during the period between calibrations is recommended. Reference antennas that are used only for calibration or comparison purposes and are not used on a daily basis should be recalibrated at least every three years. Antennas shall be calibrated using an acceptable method, such as one of the methods in IEEE Std 291-1991 or IEEE Std 149-1979. The antenna used shall be calibrated at the measuring distance at which it will be used.

NOTES

- 1—If the antenna is calibrated at a distance of $2D^2/\lambda$, it may be used to make measurements at any greater distance.
- 2—Gain standard horn antennas (sometimes called standard gain horn antennas) need not be calibrated beyond that which is provided by the manufacturer, unless they are damaged, deterioration is suspected, or they are used at a distance closer than $2D^2/\lambda$. Gain standard horn antennas have gains that are fixed by their dimensions and dimensional tolerances.

6. RF measurements

6.1 Emissions test

6.1.1 Test requirements

The equipment that is configured as described in Figure 3 is for the conducted method. If the radiated method is required, refer to the test configuration in Clause 4. The EUT is arranged to communicate via a fixed carrier frequency between its transmitter and a compatible receiver. If the devices provide two-way communications, one should be designated as the transmitter under test. If the EUT is evaluated by a conducted measurement on an external port, the EUT and its associated compatible transceiver should be placed near enough to be able to establish a connection. Tests should be performed at the manufacturer's recommended normal operating temperature and supply voltage.

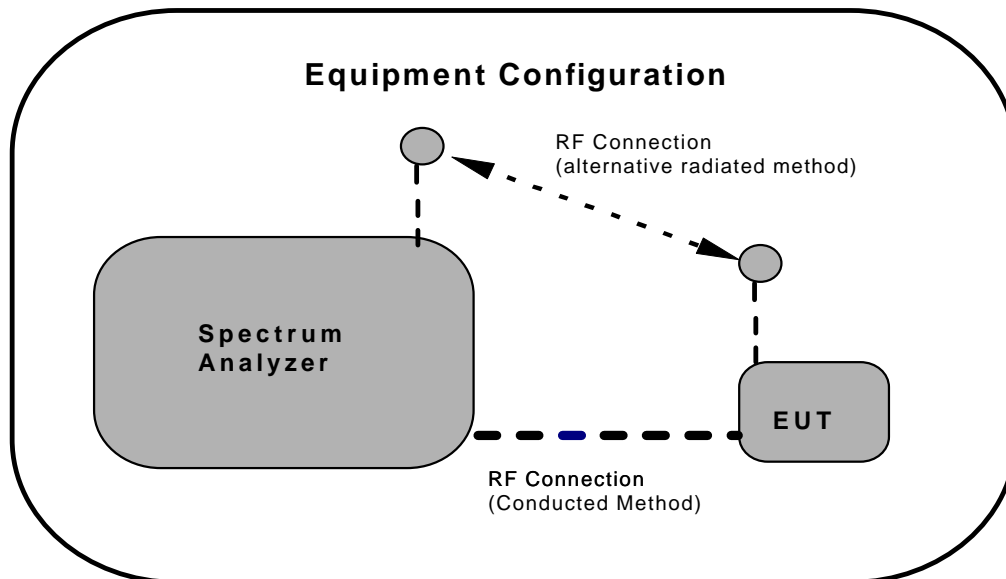

Figure 3—Test configuration

Before testing, the manufacturer shall provide to the testing organization the channel plan and declared values of the following parameters for the device being tested:

- Maximum EUT antenna gain
- Peak power level
- Free channel threshold(s)
- Emission bandwidth
- Mode of operation (isochronous or asynchronous)
- Isochronous frame period and time slot plan
- Minimum and maximum burst length for asynchronous systems

For conducted measurements, cable losses shall be taken into account. For radiated measurement, cable losses and reference antenna factors shall be taken into account.

6.1.2 Peak transmit power

For devices with an emission bandwidth within the capability (that is, less than the maximum RBW) of the spectrum analyzer to be used, the following procedure may be used.

The equipment is configured as shown in Figure 3.

Spectrum analyzer settings for determining the peak power:

RBW:	\geq emission bandwidth
Video bandwidth:	$\geq 2 \times$ emission bandwidth
Span:	0
Center frequency:	Nominal center frequency of channel
Amplitude scale:	log (linear may be used if analyzer has sufficient linear dynamic range and accuracy)
Detection:	Peak detection
Trigger:	Video

The RBW setting for this test shall be adjusted by repeating this test and using increasing values of the RBW until there are negligible changes (within ± 0.5 dB) in the measured values of the maximum power.

Alternative instrument and techniques to the spectrum analyzer may be used in measuring peak power (for example, a complex waveform analyzer or FFT signal analyzer).

6.1.2.1 Digital sequence

The digital sequence(s) used to measure peak power shall be representative of those encountered in the real system operation. If peak power is sequence-dependent, then the worst-case sequence expected to occur during normal operation shall be used.

6.1.2.2 Testing method

6.1.2.2.1 Recommended spectrum analyzer method

This method computes the transmit power over the required measurement interval using digitized samples of the waveform envelope. The spectrum analyzer sampled time-waveform data is converted to linear power.

The average of all consecutive combinations of power samples covering the interval (30/emission bandwidth) over the EUT's maximum continuous transmission interval is computed. In other words, the waveform that is the sliding power average (window filter) of width (30/emission bandwidth) for the continuous transmission interval is computed. The measurement is made over the EUT's maximum continuous transmission interval. If the maximum of the smoothed power waveform does not exceed the power limit, then the unit passes the test for that sequence. The largest of these smoothed power output values over the required sequence types is the peak transmit power.

6.1.2.2.2 Alternative spectrum analyzer method

This method uses a narrow video bandwidth to provide analog smoothing rather than using the calculated digital smoothing. The video bandwidth is set greater than or equal to the emission bandwidth/30. The averaging on a log power scale or on a linear voltage scale will give a result that is less than the true power average by an amount that depends on the variation in the amplitude envelope of the carrier. For relatively constant amplitude modulations (≤ 3 dB variation), the "scale-averaging" error is insignificant. For Gaussian noise, the amplitude envelope will have a Rayleigh distribution, and the scale-averaging error will be -2.5 dB on a log scale and -1.1 dB on a linear voltage scale. Adding a 2.5 dB or 1.1 dB correction to the result will compensate for this error. Other amplitude distributions require different corrections.

6.1.2.2.3 Alternative complex waveform analyzer or signal analyzer method

Signal analyzer settings:

Measurement type:	Vector with time correction
Center frequency:	Nominal center frequency of channel
Span (measurement BW):	> emission bandwidth ($2 \times B$ preferred)
Time record length:	> burst duration
Trigger:	Envelope
Trigger holdoff:	> burst duration
Trigger delay:	Adjust to center burst in time record
Input range:	> peak power (minimum range that will not overload the instrument)

The time data (amplitude vs. time) is obtained.

The signal analyzer time data is used to compute the peak power using the preferred method described in 6.1.2.2.1.

6.1.2.3 Standard test frequencies

If the EUT is only capable of operation on a single frequency, then that is the standard test frequency.

If the EUT is capable of operation on more than one frequency within the sub-band, then the standard test frequencies shall be the lowest frequency within the sub-band for which the device is capable of operation, the highest frequency within the sub-band for which the EUT is capable of operation, and the frequency nearest the center of the sub-band for which the EUT is capable of operation.

6.1.3 Emission bandwidth

The equipment is configured as shown in Figure 3. The EUT shall transmit in a burst mode (i.e., shall not be configured to transmit continuously), so that transient effects associated with initiation of transmission are captured by the emission bandwidth measurement.

RBW:	Approximately 1% of the emission bandwidth (a rough estimate may be obtained from peak power level measurement, or by using the manufacturer's declared value)
Video bandwidth:	≥ 3 times the RBW
Center frequency:	Nominal center frequency of channel
Span:	≥ 2 times the expected emission bandwidth
Sweep time:	Coupled to frequency span and RBW
Amplitude scale:	log
Detection:	Peak detection with maximum hold enabled

The maximum level of the modulated carrier shall be recorded. The two furthest frequencies above and below the frequency of the maximum level of the modulated carrier, where the signal level is 26 dB below the peak level of the carrier, shall be found. The difference in frequency between these two frequencies is the emission bandwidth. If, after measuring the emission bandwidth, it is found that the RBW used was not approximately 1% of the emission bandwidth, then the RBW shall be adjusted and the procedure repeated until the correct RBW is used. If the spectrum analyzer has fixed values of RBW, the one that is the nearest to 1% of the emission bandwidth is acceptable, provided that it is no less than 0.5% of the emission bandwidth and no greater than 2% of the emission bandwidth.

The frequency of the maximum level of the modulated carrier and the furthest frequencies above and below this frequency shall be recorded, where the signal levels are 6 dB, 12 dB, and 24 dB below the peak level of the modulated carrier. These three frequency pairs are to be used later in 7.4 for measuring monitoring bandwidth.

6.1.4 Modulation

Attestation of compliance with the digital modulation requirement will be made in accordance with the disclosure statement that is required by the applicable equipment authorization procedures.

6.1.5 Power spectral density using the computed average transient (CAT) method

The following test methods may be used to verify that the EUT's power spectral density does not exceed 3 mW in any 3 kHz bandwidth.

The test cases shall be representative of those encountered in the real system operation.

The equipment is configured as shown in Figure 3.

Spectrum analyzer settings:

RBW:	3 kHz
Video bandwidth:	$\geq 3 \times$ RBW
Span:	Zero span at frequency with the maximum level [frequency determined per 6.1.3 if the same type of signal (continuous vs. burst) was used in 6.1.3]
Center frequency:	Spectral peak as determined in 6.1.3

Sweep time:	For burst signals, sufficient to include essentially all of the maximum length burst at the output of a 3 kHz filter (e.g., maximum input burst duration plus 600 μ s); for continuous signals, 20 ms
Amplitude scale:	log power
Detection:	Sample detection, averaged for a minimum of 100 sweeps
Trigger:	External or internal

For burst-type signals, arrangements shall be made to measure the wideband burst duration of each burst analyzed and to compute the mean duration.

The level that is 20 dB below the first peak shall be determined. The power-averaged waveform between the 20 dB threshold levels around the first peak shall be recorded with at least 30 000 samples per second, as shown in Figure 4. Multiple wideband bursts may produce the waveform between -20 dB peaks. These shall be included in the determination of the average burst length. If there is no level that is 20 dB below the peak, then the complete sweep shall be analyzed, and all of the wideband waveform that occurs during the sweep time shall be included in the computation of average burst length.

The values of the sample points (in linear units of power) shall be summed and divided by the sample frequency to obtain the total pulse energy in the 3 kHz bandwidth. The results shall then be divided by the average duration of the wideband input pulse to obtain the average pulse power. If the result is less than 3 mW, the EUT passes the power spectral density requirement.

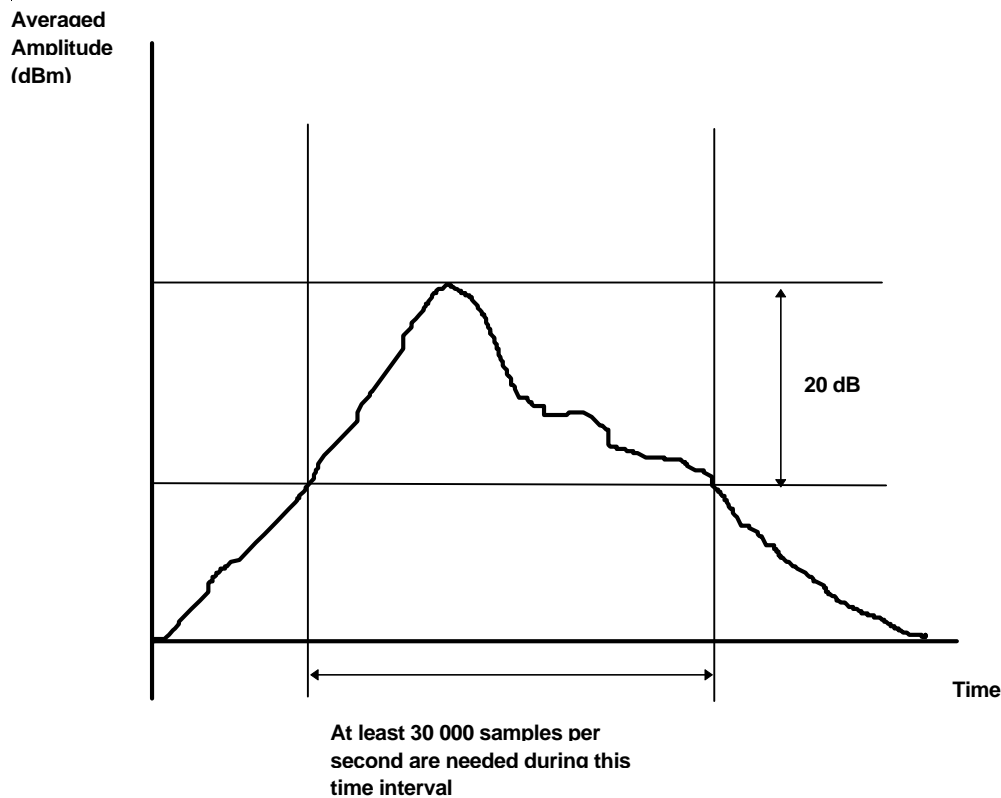

Figure 4—Computed average transient method: sampling of the averaged power waveform measured with 3 kHz resolution bandwidth

6.1.6 Emissions

Unless otherwise specified, the conducted method is the preferred method of measurement. The radiated method should be used if the EUT has a nondetachable antenna. A free-space environment or equivalent should be used in the radiated emission test. The general requirements for conducted and radiated tests are given in Clause 4.

6.1.6.1 Out-of-channel emissions

6.1.6.1.1 Channel edges

The channel edges are defined as the lowest and highest frequencies used in the UPCS device channelization scheme.

- a) *Isochronous devices*—For isochronous devices, for emissions testing purposes, the channel edges are, for example,
 - 1920 MHz
 - 1921.25 MHz
 - 1922.5 MHz
 - 1923.75 MHz
 - 1925 MHz
 - 1926.25 MHz
 - 1927.5 MHz
 - 1928.75 MHz
 - 1930 MHzFor systems that divide the channels into subchannels, the device under test shall use the subchannel that is nearest to the channel edges while the measurement is being carried out.
- b) *Asynchronous devices*—For asynchronous devices, the channel edges are, for example,
 - 1910 MHz
 - 1920 MHz
 - 2390 MHz
 - 2400 MHz

6.1.6.1.2 Measurement procedure

The equipment is configured as shown in Figure 3.

Spectrum analyzer settings:

RBW:	Approximately 1% of emission bandwidth (B) or 10 kHz, whichever is less
Video bandwidth:	$3 \times \text{RBW}$
Sweep time:	\geq pulse repetition interval multiplied by the number of trace elements
Number of sweeps:	Sufficient to stabilize the trace
Amplitude scale:	log
Detection:	Peak detection and maximum hold enabled
Span:	$1.5 \text{ MHz} \leq \text{span} \leq 5 \text{ MHz}$

The out-of-channel emission measurement starts from above or below the channel edge. The out-of-channel emission frequency range of measurement is defined in 47 CFR 15, Subpart D, 15.33. This implies that the out-of-sub-band emissions will be included in these measurements. The limits are described in 6.1.6.3.

In the region between the channel edge and 1.25 MHz above or below the channel, the measured emission level shall not exceed -9.5 dBm. In the region between 1.25 and 2.5 MHz above or below the channel, the measured emission level shall not exceed -29.5 dBm. In the region at 2.5 MHz or greater above or below the channel, the measured emission level shall not exceed -39.5 dBm.

6.1.6.2 Out-of-subchannel emissions

This test is only required for devices with an emission bandwidth of less than 625 kHz that utilize the isochronous sub-band.

The equipment is configured as shown in Figure 3.

Spectrum analyzer settings:

RBW:	Approximately 1% of the emission bandwidth (B)
Video bandwidth:	$3 \times \text{RBW}$
Sweep time:	\geq pulse repetition interval multiplied by the number of trace elements
Number of sweeps:	Sufficient to stabilize the trace
Amplitude scale:	log
Detection:	Peak detection and maximum hold enabled
Span:	Approximately equal to $3.5B$

When the test is carried out, the device under test should be on its subchannel nearest the corresponding channel edges. For example, assume a channel is subdivided into n subchannels, subchannel 1 is nearest to the lower-frequency channel edge, and subchannel n is nearest to the higher-frequency channel edge. The device shall operate on subchannel 1, and emission measurement shall start from $1B$ above the center of the emission bandwidth (B) and extend to the higher-frequency channel edge. Similarly, the device shall operate on subchannel n , and emission measurement shall start from $1B$ below the center of the emission bandwidth and extend to the lower-frequency channel edge.

In the region between $1B$ and $2B$ from the center of the subchannel, the measured emission level (measured with 1% of emission bandwidth) shall not exceed 30 dB below the permitted peak power for the device. In the region between $2B$ and $3B$ from the center of the subchannel, the measured emission level shall not exceed 50 dB below the permitted peak power for the device. In the region between $3B$ and the channel edge, as measured from the center of the subchannel, the measured emission level shall not exceed 60 dB below the permitted peak power for the device.

Where these limits are more stringent than 47 CFR 15, §15.209, these limits take precedence as indicated in 47 CFR 15, Subpart D, 15.319 (g).

6.1.6.3 Out-of-sub-band emissions

The out-of-channel emissions measurements of 6.1.6.1.2 also apply to out-of-sub-band emissions, when the subchannel or channel is set nearest to the upper or lower sub-band edge. In the region between the sub-band edges and 1.25 MHz below and above the lower and the upper sub-band edges, respectively, the measured emission level shall not exceed -9.5 dBm. In the region between 1.25 MHz and 2.5 MHz below and above the lower and the upper sub-band edges, respectively, the measured emission level shall not exceed -29.5 dBm. In the region at 2.5 MHz or greater below and above the lower and upper sub-band

edges, respectively, the measured emission level shall not exceed -39.5 dBm. 47 CFR 15, §15.209, may also be used as an option,⁹ noting that it is a radiated measurement.

UPCS devices, in general, include digital circuitry that is not directly associated with the radio transmitter and are subject to the requirements for unintentional radiators, as described in 47 CFR 15, §15.109, for both in-band and out-of-band emissions. These emissions shall be measured with the device operating in receive and transmit modes. For the transmit mode, one should not measure within 3.75 MHz of the edges of the sub-band in which the device is operating. Emissions that are directly caused by digital circuits in the transmit path do not have to meet 47 CFR 15, §15.109, limits, but rather the limits mentioned above.

6.2 Frequency and time stability

6.2.1 Test requirements

If the radiated method is used, refer to Clause 4 for configuration details. The EUT is arranged to communicate via a fixed radio channel. If the devices provide two-way communications, one should be designated as the transmitter under test. If the conducted method is used, the EUT and its companion device should be connected with shielded coaxial cable. An attenuator should be placed in the conducted path between the EUT and its companion device to prevent test results from being corrupted by emissions from the companion device. The attenuator should be adjusted to allow reliable communication between the EUT and the companion device. Tests should be performed at the manufacturer's recommended normal operating temperature and voltage.

6.2.2 Carrier frequency stability (isochronous)

The modulation analyzer or frequency and time-interval analyzer is set up as follows:

Frequency measurement:

Y axis:	Frequency
Center frequency:	Nominal carrier center frequency
Frequency span:	Span large enough so that the full waveform is greater than 50% but less than 100% of the display scale
X axis:	Time
Time setting:	Approximately transmit burst period
Measurement interval (gating time):	X (in units of bit period), where $X \leq 5000$
Number of measurements	$5000/X$ (where X is the measurement interval in units of bit period)
Trigger:	RF envelope for pulsed systems; otherwise, frequency value

The histogram of the frequency distribution shall be computed with small or negligible latency time between measurements.

The above analyzer settings will enable the mean carrier-frequency measurement to be taken over a time period of at least 5000 bits.

Alternatively, the mean frequency can be obtained using a frequency counter with the gating time set at 5000 bit periods.

⁹Compliance with the limits of 47 CFR 15, §15.209, is required in the restricted bands listed in 47 CFR 15, §15.205.

The mean value of the carrier frequency should be recorded at least once every second for a total of greater than 3000 readings or over at least a 1 h period of time. (It may be necessary to use a controller to log the measurements if the analyzer does not have that capability).

This procedure should be carried out for each of the following test cases:

Temperature	Supply voltage
20 °C	85–115% or new batteries
–20 °C*	Normal
+50 °C	Normal

* Use the lowest temperature at which the EUT is specified to operate if it is above –20 °C.

Using the mean carrier frequency at 20 °C and at nominal supply voltage as the reference, the mean carrier frequency shall be maintained within ± 10 ppm at the two extreme temperatures (or as declared by the manufacturer) and at normal temperature (typically 20 °C) at the two extreme supply voltages.

6.2.3 Frame repetition stability (isochronous)

The modulation analyzer or frequency and time-interval analyzer is set up as follows:

Frequency measurement of detected RF envelope:

X axis:	Time
Time setting:	Approximate frame period $\times 100$
Y axis:	Frequency
Center frequency:	Nominal frame-repetition rate
Frequency span:	Span large enough so that the full waveform is greater than 50% but less than 100% of the display scale
Measurement time interval (gating time):	X (in units of frame period), where $X \leq 1000$
Number of measurements:	$1000/X$ (where X is the measurement interval in units of frame period)

The histogram of the frame timing distribution shall be computed with small or negligible latency time between measurements.

The above analyzer settings will enable the mean frame-repetition rate measurement to be taken over a time period of at least 1000 frame periods. Alternatively, the mean frame-repetition rate may be obtained using an envelope detector and a frequency counter with the gating time set at 1000 times the frame period.

The mean value of the frame-repetition rate should be recorded for a total of about 1000 readings or over at least a 1 h period of time. It may be necessary to use a computer to log the measurements if the analyzer does not have that capability. A distribution of these 1000 readings should be recorded, and its standard deviation should be computed. Devices that implement time division for the purpose of maintaining a duplex connection shall maintain a frame-repetition rate whereby three times the standard deviation of the frequency stability shall not exceed 50 ppm. Each device that further divides access in time shall maintain a frame-repetition rate whereby three times the standard deviation of the frequency stability shall not exceed 10 ppm.

6.2.4 Frame period and jitter (isochronous)

The modulation analyzer or frequency and time-interval analyzer is set up as follows:

Time-interval measurement:	
Y axis:	Time
Center time:	Frame period
Time span:	Span large enough so that the full waveform is greater than 50% but less than 100% of the display scale
X axis:	Time
Time setting:	Approximate frame period \times 100
Measurement time interval (gating time):	< frame period (shall be able to measure time interval between rising edge of one pulse to the rising edge of the next pulse within a resolution of 100 ns)
Number of measurements:	1 000 000 total accumulated

The histogram of the frame-period distribution shall be computed with small or negligible latency time between measurements.

When the accumulated number of measurements reaches 1 000 000, the peak-to-peak, mean, and standard deviation values shall be recorded.

The mean value shall be the frame period and shall be 20 ms or 10 ms/ X , where X is a positive integer. Three times the standard deviation value of the jitter shall not be greater than 12.5 μ s.

Alternatively, jitter can be measured by using the analyzer to obtain the time duration between rising edges; and by using a computer to compute the difference between two consecutive frame periods. The difference between any two consecutive frame periods, measured over 1 000 000 frames, shall not exceed 25 μ s.

7. Monitoring tests

7.1 Introduction

Devices monitor their intended channel (time/spectrum window) prior to transmission to sense RF energy in the sub-band. If there is RF energy above the monitoring threshold,¹⁰ the device can either defer transmission until the channel is clear or select another clear channel. The monitoring tests in this clause verify that the monitor levels, the monitor timing, and the deferral operation are in accordance with the spectrum sharing rules.¹¹

Difficulty in definitive monitoring testing comes from several potential sources:

- Devices may be designed to operate only together with other devices of like type.
- Devices may select a new region of the sub-band or stop operating when interfering radio signals are detected in their operating region.
- Devices may transmit intermittently and, thus, their modes of operation may be difficult to detect.

¹⁰See 7.2.1 for details.

¹¹See Annex B for notes on an alternative monitoring method.

In the following tests, interference is introduced into some unused regions of the sub-band in order to confine the operation of the EUT to one region. If available, frequency-administration commands are used to confine operation of the EUT to one region. In the event of a conflict between test results obtained using frequency-administration commands and results obtained using out-of-operating-region interference, the latter results take precedence, provided that they are performed in accordance with the procedures in 7.2.4.

7.1.1 Monitoring test set-up

Figure 5 illustrates the concept of operating regions within the sub-band and shows how interference is provided outside of the operating region.

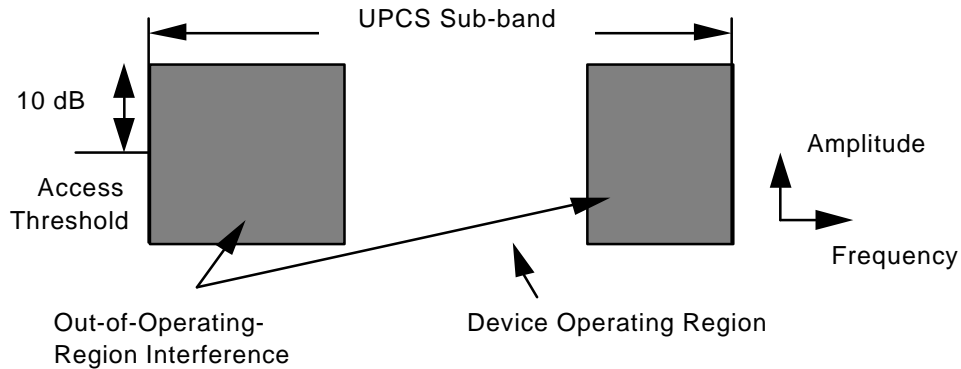

Figure 5—Operating region within UPCS sub-band

Figure 6 illustrates the concept of adding interference into the selected operating region to test for compliance with the threshold limits. With this arrangement, the test requirement is to observe if the EUT transmits in the one region where the threshold is being tested. The out-of-operating-region interference is not required during the tests if the device is designed to operate only in a fixed channel of the UPCS band, or if the device can be restricted to selected regions using frequency-administration commands.¹²

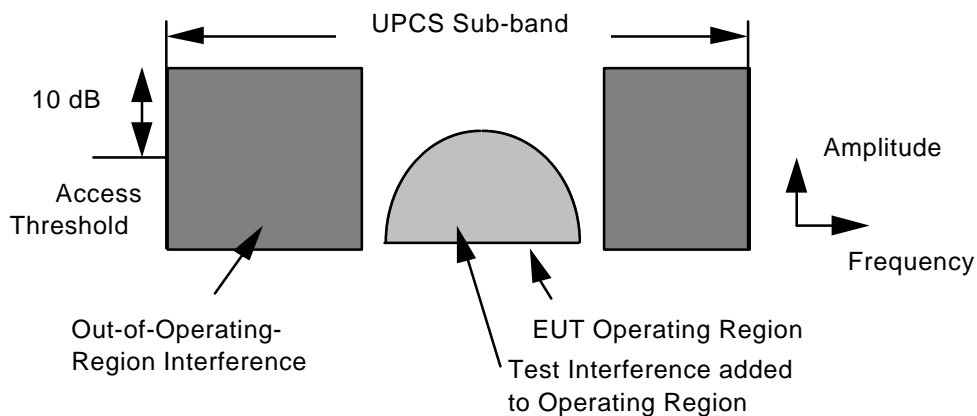

Figure 6—Interference added to operating region to test compliance

¹²For coordinatable UPCS devices, the ability to restrict the operation of the device to a subset of the available spectrum may be necessary for operation in some locations.

For the monitoring tests, the general equipment configurations are shown in Figures 7 and 8. The EUT may be arranged to communicate via radio signals between itself and another compatible device (the companion device). Typically, in the isochronous sub-band, the devices provide two-way communications, and one device should be designated as the monitoring transceiver under test (the EUT). Figure 7 illustrates radiated communication between the devices and the instruments. Figure 8 illustrates conducted communication.¹³

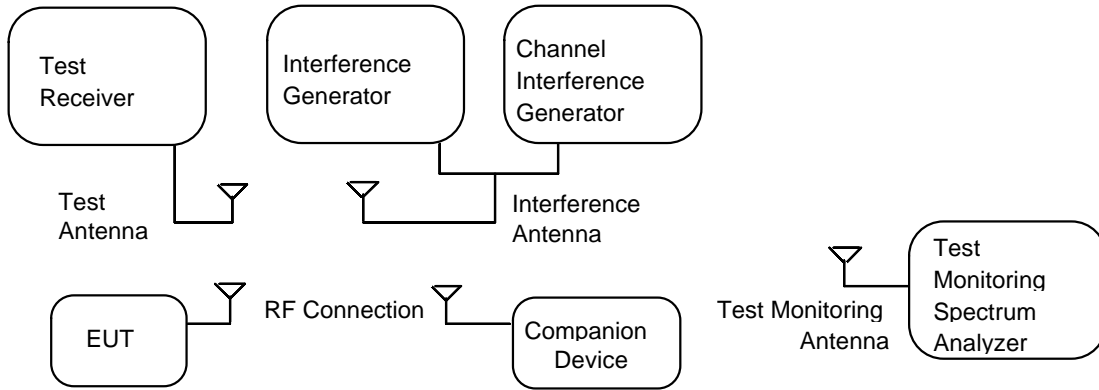

Figure 7—Equipment configuration for radiated monitoring and operational tests

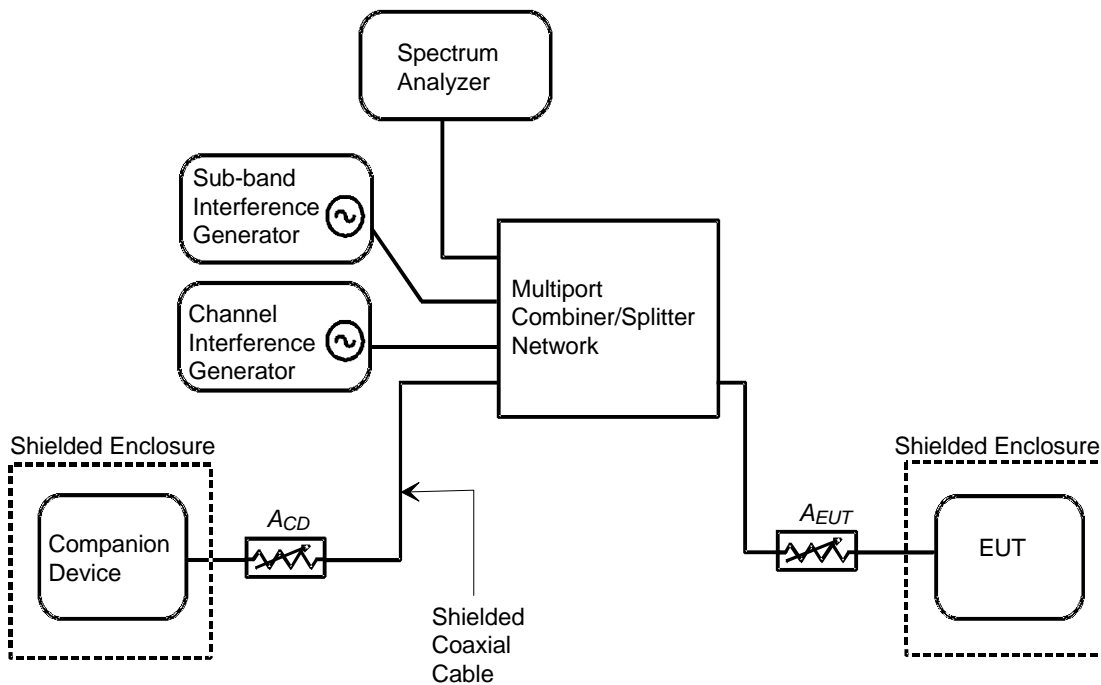

Figure 8—Equipment configuration for conducted monitoring and operational tests

¹³The interference antenna shall transmit higher power to the monitoring EUT than the companion device. Otherwise, the operation of the EUT may be masked by the undesirable deference response of the companion device.

7.1.2 Monitoring test procedure—general

The threshold used for channel access deferral is based on the power and emission bandwidth measurements of 6.1.2 and 6.1.3.

Each test generally will consist of the following steps:

- a) Using either frequency-administration commands or out-of-operating-region interference (see 7.2.4), restrict operation of the EUT to a “target” frequency or frequencies on which the test will be performed. Initiate transmission without the presence of interference on the target frequencies to verify that the EUT is operating. The communication is then stopped.
- b) Introduce interference on the target frequencies at the prescribed level and time duration as appropriate to the EUT, and verify that the EUT defers use of the region of the sub-band when it is requested to establish a connection.

The EUT passes when it operates only in the allowed combinations of operating environments.

7.2 Calibration of sensitivity

7.2.1 Calculation of thresholds¹⁴

From the results of measurements of the transmitter power level (P in dBm) and emission bandwidth (B in Hz), the threshold limits¹⁵ are calculated as follows:

Isochronous devices (lower threshold):	$15 \log_{10} B - 184 + 30 - P$ dBm
Isochronous devices (upper threshold):	$15 \log_{10} B - 184 + 50 - P$ dBm
Asynchronous devices:	$15 \log_{10} B - 184 + 32 - P$ dBm

7.2.2 Calibration of test interference field strength (radiated technique)

Refer to Clause 4 and Annex D.

7.2.3 Standard test frequencies

Refer to 6.1.6.

7.2.4 Procedures for using out-of-operating-region interference

It is assumed here that the tester has access to either

- a) An interference source capable of generating wideband interference with square spectral notches (“spectrum windows”) of variable width (i.e., the square-notch generator in 5.7), or
- b) An interference source that can generate independently-controlled (on or off) CW signals on the center frequencies of all EUT frequency channels (i.e., the multicarrier generator in 5.8).

Either generator can be used to apply out-of-operating-region interference to target specific frequency ranges for threshold testing by blocking the other frequencies, unless the selectivity of the EUT is extremely poor. The procedures given here are intended to ensure that residual power from the generator on the target (unblocked) frequency does not corrupt the test. See Annex F for background and details.

¹⁴Refer to 47 CFR 15, Subpart D, 15.321(c)(2), 15.321(c)(7), 15.323(c)(2), 15.323(c)(5), and 15.323(c)(9).

¹⁵These expressions are derived from the following formula: $kTB + 30 + (\text{allowed power} - \text{actual power})$ [units of dBm] [$k = 1.38054 \times 10^{-23}$ W/Hz/°K and $T = 290$ °K] [$kT = -174$ dBm/Hz]; see Annex D for details.

Figure 9 shows the relationships between the threshold being tested and the interference power levels discussed here. The objective is to create a situation in which the residual interference power level on the target frequency (due to imperfect frequency selectivity of the EUT) is Y dB below the threshold, while the power on the other (blocked) frequencies is X dB above the threshold (the “threshold” in these procedures for using out-of-operating-region interference refers to the actual threshold of the EUT, unless otherwise stated). If the square-notch generator is used, the power on the frequency channel(s) adjacent to the target frequency is X_A dB above the threshold, where X_A can be up to 3 dB below X , depending on the width of the notch. The equation $Z = X + Y$ represents the total dB difference between the residual interference power on the target frequency and the interference on the blocked frequencies; except for the adjacent frequencies (if the square-notch generator is used), for which the total dB difference is $Z_A = X_A + Y$. The quantities Z and Z_A depend on the EUT frequency selectivity characteristic, typically determined by the intermediate frequency (IF) filtering. The way in which Z is divided between X and Y depends on the power level applied to the EUT from the interference generator on the blocked frequencies. The procedures below determine the proper level.

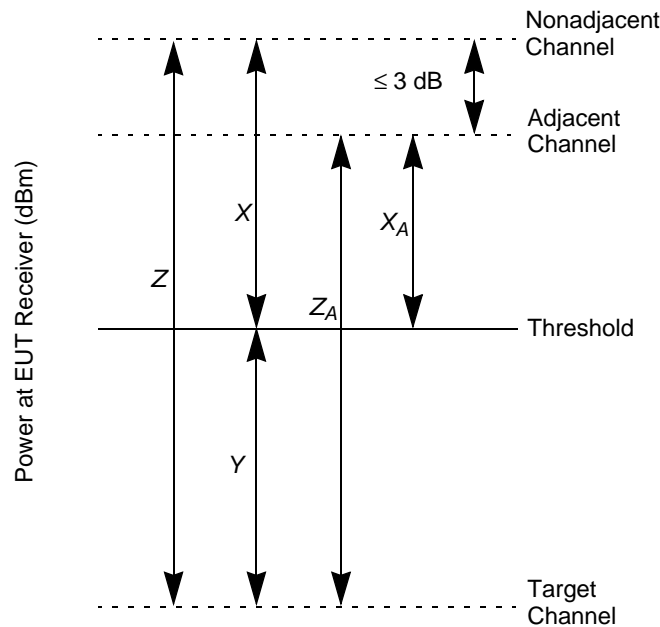

Figure 9—Relationships among power levels for out-of-operating-region interference

After out-of-operating-region interference is applied, it should be verified that the EUT is operating properly on the target frequencies.

7.2.4.1 Square-notch interference generator

7.2.4.1.1 Isochronous upper and asynchronous threshold

- a) Apply interference across the entire sub-band of interest at the maximum level, or at least 10 dB above the manufacturer’s declared threshold. Lower the interference until the EUT can transmit. The interference is now at threshold on all frequencies.
- b) Raise the interference by 25 dB and open a spectrum window (notch) centered on the target frequency. Increase the notch width until either the EUT can transmit (in which case the residual interference power on the target frequency is at the threshold), or the notch edges fall on the center frequencies of the adjacent frequency channels (as declared by the manufacturer), whichever occurs first.

- c) If the EUT transmits before the maximum notch width is reached, note that the difference between the out-of-operating-region interference and the residual interference power on the target frequency is 25 dB (i.e., $Z = 25$ dB) for the current notch width. Lower the power from the generator by 15 dB. The residual power on the target frequency is now 15 dB below the threshold (i.e., $Y = 15$ dB), and the interference power on the blocked frequencies, except for the adjacent frequency, is 10 dB above the threshold ($X = 10$ dB). The interference power on the adjacent frequencies is at least 7 dB above the threshold ($X_A \geq 7$ dB).
- d) If the EUT could not transmit with the notch edges at the center frequencies of the adjacent frequencies, lower the power until the EUT can transmit (so that the residual interference power on the target frequency is at the threshold). Z is the dB difference between the generator PSD at that point and the threshold, and Z_A is 3 dB less. Lower the interference power by 15 dB or $Z - 6$ dB, whichever is less (this ensures that X_A is at least 3 dB). The amount of the reduction is Y dB (i.e., the residual interference power on the target frequency is now Y dB below the threshold). If Y is less than 10 dB, a correction factor shall be applied to the test results. If a test signal of power level S dBm causes deference, then the actual threshold is:

$$T = S - 10\log(1 - 10^{-Y/10}) \quad (7)$$

The abscissa of Figure F.1 in Annex F corresponds to $-Y$, and the ordinate corresponds to $S - T$ (the dB difference between the measured and actual thresholds).

Make note of the value of Z , the corresponding notch width, W_N , and the value of Y .

7.2.4.1.2 Isochronous lower threshold and least-interfered channel

- a) With the interference generator configured to apply interference on the frequency channels that overlap either the upper or lower 3 MHz of the band (depending on the emission bandwidth of the EUT), set the generator power level at the EUT (using attenuators if necessary) to 10 dB below the manufacturer's declared lower threshold. Verify that the EUT transmits on a frequency channel overlapping the 3 MHz at the appropriate end of the band. Raise the generator power level until the point is found at which the EUT transmits on a frequency not overlapping the first 3 MHz. The interference power is at the lower threshold on the blocked frequencies.
- b) Open two notches in nonadjacent frequency channels, each of a width of W_N (as determined above). Neither channel should overlap the 3 MHz at the preferred end of the band. For the lower threshold test, set the generator PSD to X dB above the lower threshold, where X is 6 dB or $Z - 15$ dB, whichever is greater, and Z is the value determined above. If $Y (= Z - X)$ is less than 10 dB, use the correction factor in Equation (7) to compute the actual lower threshold.
- c) For the least-interfered channel test, increase X to 15 dB (raise the interference power on the blocked channels to 15 dB above the lower threshold) and compute $Y = Z - 15$ dB. If Y is less than 7 dB, the test signal used in the least-interfered channel shall be adjusted such that the total power is 3 dB above the lower threshold. The power, S , of the test signal into the EUT, in dB above the lower threshold, is computed using

$$S = 10\log(2 - 10^{-Y/10}) \quad (8)$$

7.2.4.2 Multicarrier interference generator

7.2.4.2.1 Isochronous upper and asynchronous threshold

- a) Apply interference on all system carriers at the maximum level. Lower the interference uniformly on all carriers until the EUT can transmit. The interference is now at the threshold on all frequencies.
- b) Raise the interference by 25 dB and remove the interfering carrier on the target frequency. If the EUT can transmit, then the residual interference on the target frequency is at or below the threshold;

and the difference between the out-of-operating-region interference and the residual power on the target frequency is at least 25 dB (i.e., $Z \geq 25$ dB). If the EUT cannot transmit on the target frequency, skip to the next step. Reduce the interference power on all active carriers by 15 dB, so that $X = 10$ dB (the interference power on the blocked frequencies is 10 dB above the threshold) and $Y \geq 15$ dB (the residual interference power on the target frequency is at least 15 dB below the threshold), and proceed with the test. Make note of the fact that $Z \geq 25$ dB.

- c) Lower the power until the EUT can transmit on the target frequency, which indicates that the residual interference power on the target frequency is just below the threshold. Make a note of Z , which is the dB difference between the carrier power (on the blocked frequencies) at which the EUT can transmit and the threshold determined in step a).
- d) Reduce the interference power by 15 dB, or $Z - 3$ dB, whichever is less. The amount of the reduction (in dB) is Y . The residual power on the target frequency is now Y dB below the threshold. Proceed with the threshold test on the target frequency. If Y is less than 10 dB, the correction factor in Equation (7) shall be used to determine the threshold.

7.2.4.2.2 Isochronous lower threshold and least-interfered channel

- a) Apply interfering carriers on the center frequencies of all frequency channels that overlap either the upper or lower 3 MHz of the band (depending on the emission bandwidth of the EUT), and set the power level (per carrier) to 10 dB below the manufacturer's declared lower threshold. Verify that the EUT transmits on a frequency channel overlapping the first 3 MHz at the appropriate end of the band. Raise the power on the interfering carriers until the point is found at which the EUT transmits on a frequency not overlapping the first 3 MHz. The power level per carrier is at the lower threshold.
- b) Apply interference to all carriers except for two nonadjacent frequencies, neither of which overlaps the 3 MHz at the preferred end of the band. For the lower threshold test, set the power on the active interfering carriers to X dB above the lower threshold, where X is 3 dB or $Z - 15$ dB, whichever is greater, and Z is the value determined above. If $Y (= Z - X)$ is less than 10 dB, use the correction factor in Equation (7) to compute the actual lower threshold.
- c) For the least-interfered channel test, increase X to 12 dB and compute. If Y is less than 7 dB, the test signal, S , used on the least-interfered channel shall be adjusted such that the total power is 3 dB above the lower threshold. The power, S , of the test signal into the EUT, in dB above the lower threshold, shall be computed using Equation (8).

7.3 Threshold level

7.3.1 Asynchronous devices¹⁶

For devices utilizing the asynchronous sub-band,

- a) In the initial state, with no interference, verify that the EUT transmits.
- b) Using frequency-administration commands or out-of-operating-region interference (following the procedures in 7.2.4), restrict operation of the EUT to a single system-frequency channel, and verify that the EUT can transmit.
- c) Introduce a CW signal at the calculated threshold limit on the center frequency of the target channel. The success criterion is that the EUT does not transmit.

¹⁶Refer to 47 CFR 15, Subpart D, 15.321(c)(2).

7.3.2 Isochronous devices¹⁷

7.3.2.1 Determination of thresholds and verification of “best channel” selection

These tests determine the lower and upper thresholds of the EUT, and verify that if the EUT is operating in the “least-interfered channel” mode, it can properly select the channel with the lowest interference power, within a 6 dB resolution. The “preferred” end of the 1920–1930 MHz band denotes the end at which the search for channels with interference below the lower threshold shall begin. For devices with an emission bandwidth of less than 625 kHz, the search shall begin within 3 MHz of the lower end of the band (i.e., 1920 MHz). For devices with an emission bandwidth of greater than 625 kHz, the search shall begin within 3 MHz of the upper end of the band.

Some types of devices (in some modes) can transmit without establishing a connection (for example, devices transmitting signaling beacons). For those devices, no companion device is necessary for these tests. Other types of devices (or other operating modes) need to establish a connection to transmit continuously, and a companion device is required to perform the tests. In these cases, the interference to the companion device should be at least 10 dB lower than the interference to the EUT. If a companion device is needed, the path loss between the EUT and the companion device shall be adjusted such that the signal received from the companion device exceeds the interference in the target channels by a sufficient margin to allow reliable communication. Otherwise, the behavior of the EUT might be influenced by poor received-signal quality. In any of the following steps, if the EUT fails to transmit when it should (according to the manufacturer’s declared thresholds and operating protocols), any necessary adjustments shall be made in the path loss between the EUT and companion device and the out-of-operating-region interference, and the step shall be repeated.

The manufacturer shall include in its test report a declaration of the relevant monitoring thresholds, as well as an explanation of the monitoring and channel-selection protocols, including any necessary diagrams.

The steps that follow apply directly to conductive testing. For radiative testing, the threshold power levels specified in the following subclauses shall be translated to the corresponding transmit power levels for the reference antenna, as discussed in Clause 4 and Annex D.

The interference test signals either may be CW or may be modulated in the same way as the EUT transmission. The out-of-operating-region interference (if used) should be adjusted to the levels appropriate to the test (i.e., lower threshold, least-interfered channel, upper threshold) as discussed in 7.2.4.

When these tests are performed on an EUT that is transmitting signaling or control information, transmission on an existing channel (initiated before the interference is applied) may continue for up to 30 s before channel selection is effected by the interference. For such devices, it may be necessary to wait for 30 s to verify proper monitoring and to establish the threshold being measured. Similarly, the device should continue to transmit on a channel consistent with the interference that is applied as long as the interference exists.

7.3.2.1.1 Lower threshold

- a) Using either frequency-administration commands or out-of-operating-region interference, allow operation on only two of the EUT’s carrier frequencies, neither of which overlap the 3 MHz nearest the preferred end of the band. The carrier nearest the preferred end of the band will be designated f_1 , and the other carrier will be designated f_2 .
- b) With no interference on either carrier, initiate transmission. Transmission should occur on f_1 .
- c) If a connection exists, terminate it. Introduce interference to the EUT on f_1 at a level of 10 dB below the manufacturer’s declared lower threshold. Initiate transmission and determine whether transmis-

¹⁷Refer to 47 CFR 15, Subpart D, 15.323(b), 15.323(c)(2), and 15.323(c)(5).

- sion occurred on f_1 or f_2 . If it occurred on f_2 , then lower the interfering signal level on f_1 and repeat the above.
- d) If a connection exists, terminate it and raise the interference on f_1 by 1 dB. Initiate transmission. Determine whether transmission occurred on f_1 or f_2 .
 - e) Repeat the previous step until transmission occurs on f_2 . The highest interference level at which transmission occurs on f_1 is the measured lower threshold.
 - f) Record the value of the measured lower threshold for use in subsequent tests and terminate the connection.
 - g) If the measured lower threshold, in dBm, is more than $15 \log_{10} B - 154 - P_{EUT}$, where B is the emission bandwidth of the device, in Hz, and P_{EUT} is the transmitted power, in dBm, the device fails the test.¹⁸
 - h) If the EUT has less than 40 channels, perform this step. Otherwise, proceed with the least-interfered channel test that follows. If a connection exists, terminate it. Apply interference to the EUT on f_1 and f_2 at the calculated lower threshold limit, as determined previously. The interference on f_1 shall occur only during the transmit portion of the EUT's frame; the receive portion shall be interference-free. The interference on f_2 may be continuous. Initiate transmission. If the EUT transmits, it fails the test.

7.3.2.1.2 Least-interfered channel

- a) If a connection exists, terminate it. Apply interference to the EUT on f_1 at a level that is 10 dB above the measured lower threshold, and on f_2 at a level that is 3 dB above the measured lower threshold. Initiate transmission. The EUT should transmit on f_2 . If it transmits on f_1 , it fails the test. If it does not transmit on f_2 , and a companion device is necessary, make whatever adjustments are necessary to the path loss between the EUT and the companion device to allow an adequate carrier-to-interference ratio, and repeat the test.
- b) If the system uses time-division multiple access (TDMA), perform this step. If a connection exists, terminate it. Remove the interference from a single slot on f_1 , so that all of the EUT's slots on f_1 have an interference of 10 dB above the measured lower threshold except for one slot, which is interference-free. (At the manufacturer's option, the interference may be applied only to the transmit or receive portion of the EUT's frame, with a single transmit slot clear.) The interference on f_2 should be 3 dB above the measured lower threshold. Initiate transmission. The EUT should transmit on the interference-free slot on f_1 . Otherwise, the EUT fails the test.
- c) If a connection exists, terminate it. Apply interference on f_2 at a level that is 10 dB above the measured lower threshold, and on f_1 at a level that is 3 dB above the measured lower threshold. Initiate transmission. The EUT should transmit on f_1 . If the EUT transmits on f_2 , it fails the test.

7.3.2.1.3 Upper threshold

- a) If a connection exists, terminate it. Apply interference to f_2 at a level that is 10 dB above the manufacturer's declared upper threshold. Apply interference to f_1 at a level that is 10 dB below the manufacturer's declared upper threshold during only the transmit portion of the EUT's frame.
- b) Initiate transmission, and observe whether the EUT transmits. If a connection is made, terminate it and increase the interference on f_1 by 1 dB.
- c) Repeat the previous step until the EUT fails to transmit. The lowest level of interference on f_1 at which the EUT will not transmit is the measured upper threshold.
- d) Record the value of the measured upper threshold for future reference.
- e) If the measured upper threshold, in dBm, exceeds $15 \log_{10} B - 134 - P$, where B is the emission bandwidth, in Hz, and P is the transmitted power, in dBm, the test is failed.
- f) If the measured upper and lower thresholds are separated by more than 26 dB, the test is failed.¹⁹

¹⁸Refer to 47 CFR 15, Subpart D, 15.323(c)(2).

¹⁹This maximum separation includes the nominal 20 dB separation plus a 6 dB measurement tolerance.

7.3.2.2 Selected channel confirmation²⁰

Some types of devices may pre-scan available time/spectrum windows and store the detected power levels in memory to facilitate fast selection of a time/spectrum window when access is required. Since some amount of time is required for a complete scan,²¹ the stored power level for a selected time/spectrum window may have “aged” since the measurement was taken. The device is therefore required to remonitor the selected time/spectrum window immediately prior to transmission. The test described below is intended to verify that the EUT makes its channel-selection decision on the basis of a recent power-level reading. The manufacturer shall describe the channel monitoring and selection process used by the EUT, including details regarding the time between monitoring and transmission on the confirmed channel. Appropriate timing diagrams shall be included as necessary.

Out-of-operating-region interference, if used, should be set at levels appropriate to the least-interfered channel test.

- a) Using the same setup as the previous test, set the interference to the EUT on f_1 to a level that is 3 dB above the measured lower threshold, and on f_2 to a level that is 10 dB above the measured lower threshold. Temporarily remove the RF signal on f_2 (e.g., by turning off the RF on the generator front panel, while leaving the generator on).
- b) Initiate transmission and verify that the EUT transmits on f_2 . If a connection was made, terminate it.
- c) Re-apply the RF signal on f_2 and immediately cause the EUT to attempt transmission. The EUT should now transmit on f_1 .
- d) If the device transmits on f_2 , it fails. If the device transmits on f_1 , it passes.

7.4 Threshold monitoring bandwidth

Using either frequency-administration commands or out-of-operating-region interference (following the procedures in 7.2.4), operation of the EUT shall be restricted to a single system-carrier frequency, and it shall be verified that the EUT can establish a connection. If out-of-operating-region interference is used, the levels shall be appropriate to the “upper threshold” test for isochronous devices with more than 40 channels. For isochronous devices with less than 40 channels, the levels for the “lower threshold” test shall be used. The test shall be performed for each standard test frequency on which the EUT is capable of operation.

7.4.1 Simple compliance test

The following test may be used to verify that the EUT complies with the rules. While this procedure verifies compliance using a simple test, failure does not indicate that the EUT fails to comply with the rules. If this test fails, the more complex test below may be used; however, this test is more severe than required and more severe than the more detailed test alternative below.

Center the interfering signal at a frequency above the center of the emission of the EUT, separated by 40% of the emission bandwidth of the EUT, at a level that is 4 dB above the calculated threshold limit.²² The bandwidth of the interfering signal shall be equal to or greater than the minimum emission bandwidth allowed for the sub-band. It shall be verified that the EUT does not establish a connection. The procedure is repeated with the interference centered at a frequency below the center of the emission of the EUT, separated by 40% of the emission bandwidth of the EUT, at a level that is 4 dB above the calculated threshold limit. It shall be verified that the EUT does not establish a connection.

²⁰Refer to 47 CFR 15, Subpart D, 15.323(c)(1) and 15.323(c)(5).

²¹Up to 10 s is allowed for devices operating under 47 CFR 15, Subpart D, 15.323(c)(5).

²²For devices operating in the isochronous sub-band, the calculated upper threshold limit shall be used if the EUT has more than 40 channels. Otherwise, the calculated lower threshold limit shall be used.

7.4.2 More detailed test

The following (more detailed) test verifies the operation of the EUT by probing the shape of the emissions and the monitoring filter.

From the measurement of the emission bandwidth (see 6.1.6), the three frequency pairs shall be found above and below the frequency of the maximum level of the modulated carrier, most removed from each other, where the signal levels are 6 dB, 12 dB, and 24 dB below the peak level of the modulated carrier. With an unmodulated interfering signal set at each of these frequencies and set at a level 6 dB, 12 dB and 24 dB above the calculated threshold limit,²³ it shall be verified that the EUT does not establish a connection. The following table summarizes these test frequencies and levels.

Test frequency	Test level (above threshold limit)
-6 dB points	6 dB
-12 dB points	12 dB
-24 dB points	24 dB

NOTE—The test at the center frequency is equivalent to part of the test of 7.3.2.

7.5 Isochronous reaction time and monitoring interval²⁴

In the isochronous sub-band, the reaction time is the duration of the RF power, during the monitoring interval, that shall be detected by the device to determine that the monitored time and spectrum window is occupied. The objective of the test is to demonstrate that the device defers use of a region of spectrum when the interfering signals are of a time duration that exceeds the allowed limit. An example of a radiated arrangement of the test equipment is shown in Figure 10 (a similar conducted arrangement could be used). The gate device may be a controlled amplifier that is used to pulse the channel interference to provide pulses of the required time duration and position. An alternative arrangement would be to connect the output of the pulse generator directly to the pulse-modulation input of the channel interference generator, if it is so equipped.

- a) Using either frequency-administration commands or out-of-operating-region interference (as discussed in 7.2.4), restrict the EUT to operation on a single system-carrier frequency, and verify that the EUT can establish a connection. If out-of-operating-region interference is used, the levels shall be appropriate to the “upper threshold” test for isochronous devices with more than 40 channels. For isochronous devices with less than 40 channels, use the levels for the “lower threshold” test.
- b) The level of the interference may be set with an unmodulated signal, followed by the application of the appropriate modulation (if necessary). A pulsed CW signal may also be used. The channel interference should be pulsed with a 10 ms repetition period²⁵ and a variable pulse width.²⁶ As some devices may divide the use of the channel, in time, into a number of time slots, it may be necessary for the pulsed interference to be timed to correspond to the time-slot pattern in the frame of the EUT. If this is necessary, the manufacturer shall supply the necessary frame-pattern information including the frame period and the number and duration of the time slots.

²³For devices operating in the isochronous sub-band, the calculated upper threshold limit shall be used if the EUT has more than 40 channels. Otherwise, the calculated lower threshold limit shall be used.

²⁴Refer to 47 CFR 15, Subpart D, 15.323(c)(1) and 15.323(c)(7).

²⁵The accuracy of the repetition rate should be ± 10 ppm or better.

²⁶The rise and fall times of the interference bursts shall be less than 1 μ s from 10–90% of the final amplitude. The interference pulse shall be of constant amplitude during its burst ($\pm 5\%$).

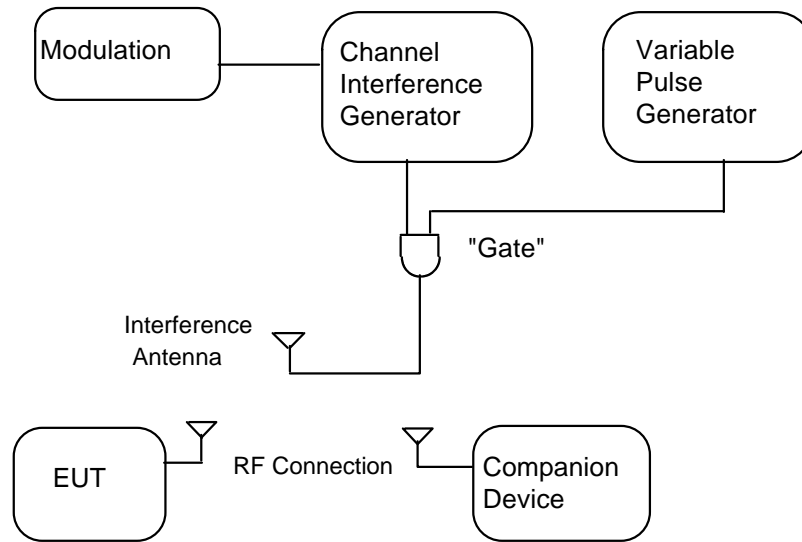

Figure 10—Example arrangement for testing of isochronous monitoring reaction time

NOTE—A “timeslot” here refers to a subdivision of the EUT frame interval to support multiple users on a single carrier frequency using time-division multiple access (TDMA). It does *not* refer to the subdivision of a 10 ms interval into multiple frames. For example, assume that the duration of the EUT frame is $10/X$ ms, where X is a positive integer, and each frame is divided into N timeslots. For the test, there should be N interference pulses per 10 ms interval, *not* NX pulses. The timing of the pulses should be arranged such that each of the N timeslots receives one pulse in 10 ms, *not* one pulse per EUT frame (unless, of course, the EUT frame duration is 10 ms).

- c) With the channel-interference level at the calculated threshold limit,²⁷ verify that the EUT does not establish a connection when the width of the interference pulse exceeds $50\sqrt{1.25/B}$ μs , where B is the emission bandwidth of the EUT, in MHz.
- d) With the channel interference set to a level that is 6 dB above the calculated threshold limit, verify that the EUT does not establish a connection when the width of the interference pulse exceeds $35\sqrt{1.25/B}$ μs , where B is the emission bandwidth of the EUT, in MHz.
- e) Increase the pulse duration to $75\sqrt{1.25/B}$ μs , where B is the EUT emission bandwidth, in MHz. Set the interference power to a level 10 dB above the calculated upper threshold limit and randomly vary the synchronization of the pulsed interference generator with respect to the EUT frame. Verify that the EUT does not transmit (note that the time between interference pulses on successive frames shall not exceed 10 ms).

Repeat steps a) through e) for each standard test frequency within the sub-band for which the EUT is capable of operation.

²⁷For devices operating in the isochronous sub-band, the calculated upper threshold limit shall be used if the EUT has more than 40 channels. Otherwise, the calculated lower threshold limit shall be used.

7.6 Asynchronous spectrum access procedures

The EUT should be adjusted to transmit packets at a high rate. If two or more devices generate a cooperative burst, then the time zero in Figure 11 is the end of the cooperative burst.

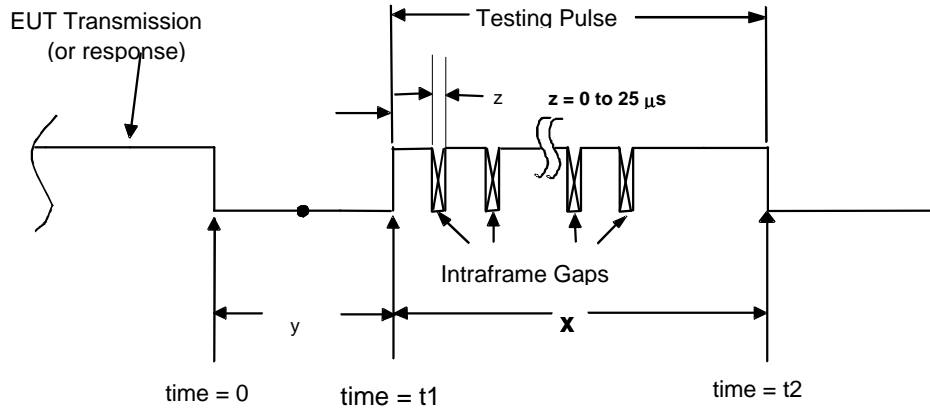

Figure 11—Asynchronous spectrum access procedure tests sequence illustration

Test pulses, when required, shall be generated by the test system of Figure 12 or its equivalent. The test system has a means of monitoring and synchronizing to the packet-end condition (time = 0 in the illustration) and varying the delay, y , before the test pulses begin. The test system shall be capable of sensing a transmission from the EUT during the testing pulse. It shall also be capable of measuring the duration of transmissions from the EUT.

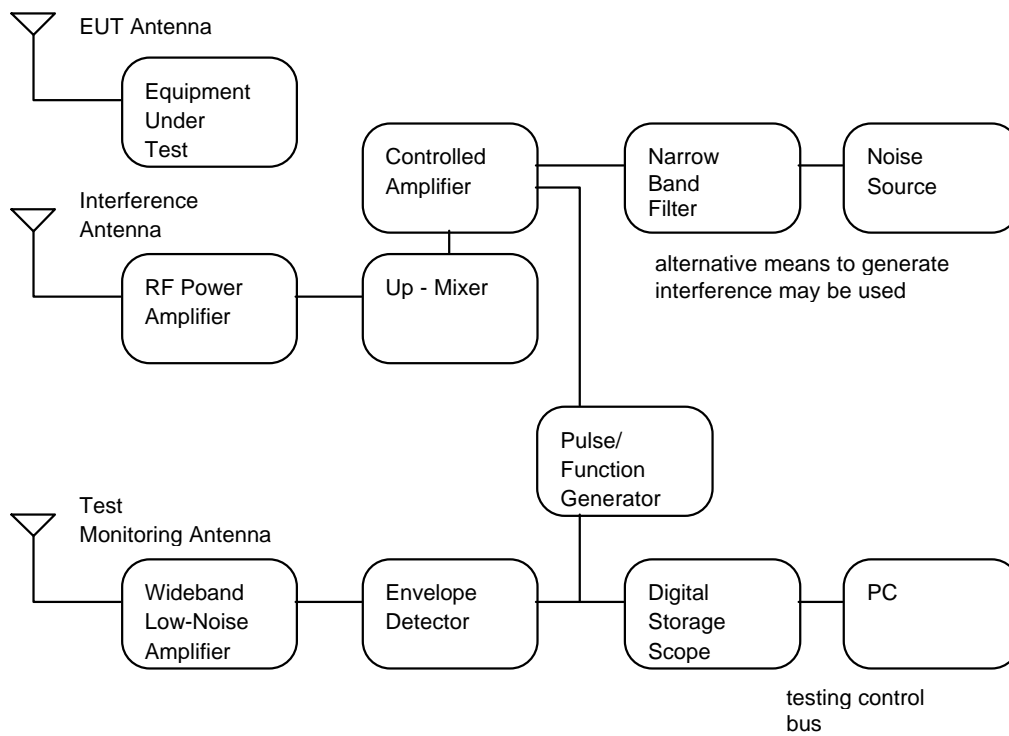

Figure 12—Configuration for asynchronous procedures spectrum access tests

7.6.1 Asynchronous access procedures state diagram

As shown in Figure 13, the device enters the Monitor state from the Idle state, typically when a packet is queued for transmission. Before exiting the Monitor state, the device is required to have monitored received power, on the frequency channel it intends to use, for at least 50 μs .

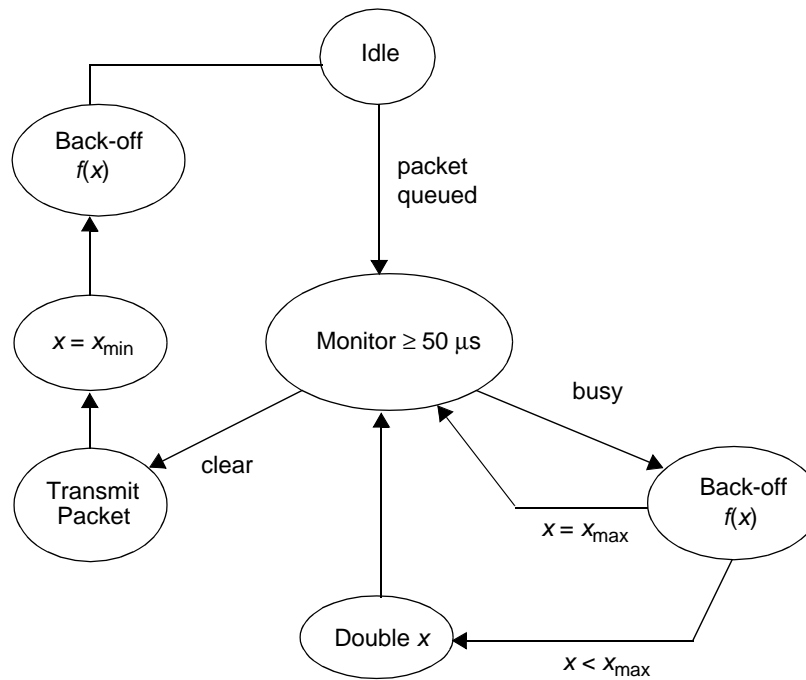

Figure 13—Asynchronous access procedures state diagram

NOTE— $f(x)$ is a number greater than or equal to a uniform random number from the range $[50 \mu\text{s}, x]$ with $x_{\min} = 750 \mu\text{s}$ and $x_{\max} = 12 \text{ ms}$.

At the end of the monitoring period, the device shall make a hard decision to transmit (if the channel is judged clear) or to defer (if the channel is judged busy).

The channel may be judged clear if a 15 μs sliding time average of received power is below threshold throughout the monitoring period; otherwise, the channel shall be judged busy.

After the end of a (clear) monitoring period, there may be a delay before the EUT begins transmitting. This delay is the reaction time—the interval from the end of an observation window to the beginning of the transmission. Reaction time is required to be less than 50 μs .

The Back-off state occurs in two locations in the diagram. In this state, the device sets a time-out value, awaits the end of the time-out, then exits the state. The time-out interval is required to be equal to or larger than a random variable that is uniformly distributed between 0 and x , where x has a minimum value of 750 μs and a maximum value of 12 ms. The diagram shows how the variable, x (i.e., the range of the uniform distribution), is increased between 750 μs and 12 ms. The device delays a random interval, the minimum value of which is controlled by x , then exits the Back-off state. Although the diagram shows the device starting its monitor interval after the end of the deference interval, it is acceptable to start the monitor interval earlier. It is required, however, that the monitoring interval include the 50 μs immediately after the random deference interval.

If the frequency channel is busy when the device exits the Monitor state, the value of the variable, x , is compared to the maximum value that it may assume (12 ms). If x is less than the maximum value, x is doubled or set equal to 12 ms, whichever is less, and the Back-off state is entered. If x is equal to the maximum value when the Monitor state is exited, the Back-off state is entered directly. After executing the back-off, the Monitor state is re-entered.

If the frequency channel is clear when the Monitor state is exited, the packet is transmitted, x is reinitialized to the minimum value, and the Idle state is re-entered. If another packet is queued, the device immediately enters the Monitor state from the Idle state; otherwise, the device waits for another packet queued condition, then enters the Monitor state.

Although not shown in Figure 13, it is permitted for monitoring to occur during the Idle state in anticipation of a packet arriving on the queue for transmission. If the channel has been monitored for at least the 50 μ s immediately preceding the packet arrival, then the clear/busy decision can be made immediately upon the packet's arrival.

7.6.2 Asynchronous burst length

Asynchronous transmission bursts are periods of RF energy sometimes separated by short, intraburst gaps of no energy. The end of a burst is indicated by a period of no energy of a duration exceeding 50 μ s. The objective of this test is to verify that the EUT burst transmission length does not exceed the specified burst-length limit.

Refer to Figure 11. The testing unit pulse is not required for this test.

The manufacturer shall state the conditions and number of devices necessary to stress the upper limit of the burst interval.

Under these appropriate conditions, The durations of a sufficient number of transmission bursts shall be measured, including any intraburst gaps, to show that the EUT meets the maximum burst-length specification of 10 ms or less.

7.6.3 Asynchronous reaction time and burst timing

In the asynchronous sub-band, the reaction time is the time from the end of an observation window, in which the device has detected no power above the threshold, until the device begins transmission. One objective of the test is to determine that the reaction time does not exceed the allowed limit of 50 μ s.

The device shall also recognize intraburst gaps from other devices and defer transmission until the end of the burst. Intraburst gaps may be separated by 15 μ s or less. A further objective of this test is to verify that the EUT recognizes the limit of the intraburst gap and pulse length and defers transmission until the end of a burst in progress.

The equipment may be configured as shown in Figure 12. Figure 11 illustrates the test parameters.

The test equipment generates a test pulse consisting of a sequence of intraburst gaps separated by ON pulses, whose durations alternate 15 μ s, 100 μ s, etc., as illustrated in Figure 14. Thus, a sequence would be 15 μ s ON followed by the following repeated sequence: 25 μ s OFF, 15 μ s ON, 25 μ s OFF, 100 μ s ON, 15 μ s OFF, 25 μ s ON, 25 μ s OFF, 15 μ s ON repeated for the testing unit pulse duration.

- a) The value of y is set larger than the delay before the EUT begins its deference interval to access the media for the next packet. The EUT is permitted to delay before it begins a back-off interval, and it is necessary in this test that it start the deference interval at least one monitoring time prior to the beginning of the testing unit pulse. This ensures that the EUT will sometimes be monitoring when

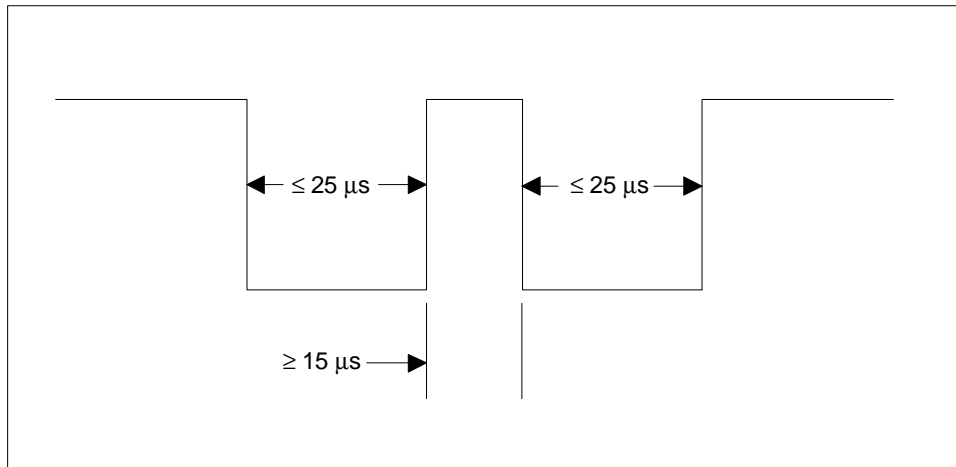

Figure 14—Detail of a pair of intraframe gap sequences for asynchronous burst timing tests

NOTE—The EUT is required to defer to silent periods of $\leq 25 \mu\text{s}$ duration, separated by RF bursts of $\geq 15 \mu\text{s}$ duration. A pair of such intraburst gaps is illustrated here.

the test pulse starts. The necessary value of y can be found by setting the start of the test pulse at about the $100 \mu\text{s}$ point ($y = 100 \mu\text{s}$) and increasing the duration, if necessary, until the start of the next EUT packet sometimes begins prior to the start of the test pulse.

- b) Set the testing unit pulse length shown in Figure 11 to 10 ms.
- c) Test at least 1000 bursts. The EUT shall not start a transmission in the interval starting $65 \mu\text{s}$ after the beginning of any simulated burst and lasting until $75 \mu\text{s}$ following the simulated burst.

7.6.4 Back-off time distribution

This test verifies compliance with the intent of 47 CFR 15, Subpart D, regarding the probability and timing aspects of the channel access procedure (see Figure 13). The following are verified:

- a) The back-off range
- b) The doubling of the back-off range
- c) The uniformity of the back-off range probability density
- d) The monitoring interval

The test does not address each parameter explicitly; rather, it statistically compares the observed behavior of the EUT with the (simulated) behavior of the state machine of Figure 13.

Test equipment is arranged so that the silent intervals between EUT transmissions may be observed, measured, and recorded as a histogram. The EUT is adjusted to transmit packets at its maximum rate. At the end of each EUT transmission (or transmission burst), the EUT is illuminated with an interference pulse of (uniform) random duration. A clock is started after the interference pulse ends. The interference pulse is received well above the legal threshold power and, thus, causes a compliant EUT to defer. The EUT will eventually execute a monitoring window in which there is no interference and, thus, will transmit another packet. At that point, the silence-interval clock is stopped and read, and the appropriate histogram bin is incremented.

After the specified number of repetitions (i.e., EUT transmissions), the accumulated histogram is normalized to a probability density estimate on the duration of the silent interval. It is then integrated to a probability distribution estimate. From this is subtracted, bin by bin, a similar quantity calculated for the state diagram of Figure 13 (see Annex E). If any one of the histogram bins is more than 105% of the reference value generated by the program of Annex E, with input values of 20 000 repetitions and 12 000 μ s maximum pulse length, then the EUT fails the histogram test; otherwise, it passes.

7.6.4.1 Histogram test parameters

Interference pulse duration:	Uniform random between 0–12 ms
Histogram bin width:	10 μ s
Number of histogram bins:	2400
Number of repetitions:	20 000
Allowable bin excess:	5%

8. Time and spectrum window access procedure

8.1 Time and spectrum window selection

8.1.1 Asynchronous time and spectrum window selection²⁸

For devices that utilize the asynchronous sub-band with emission bandwidths under 2.5 MHz, and that do not dynamically change the region of the sub-band used for their operation, it shall be verified that their frequency can be set to the region of the band required for first spectrum occupancy.

For devices that utilize the asynchronous sub-band and that can dynamically change the region of the sub-band used for their operation:

- a) Place the EUT and its companion device in the test location.
- b) Arrange for there to be no interference or any other activity in the UPCS band in the EUT operating environment.
- c) Verify that the EUT transmits, when in a mode of sending packets continually, as follows:
 - For devices with an emission bandwidth less than 2.5 MHz, the EUT transmits in a region of the sub-band within the limit from the edges of the sub-band.
 - For devices with an emission bandwidth greater than 2.5 MHz, the EUT transmits in a region of the sub-band within the center half of the sub-band.
- d) For devices of less than 2.5 MHz emission bandwidth, arrange for there to be interference in the sub-band that exceeds the threshold level by 10 dB in the region near the sub-band edge where the EUT first selects to operate without interference.
 - Verify that the EUT transmits, when in the mode of sending packets continually, within the limits near the opposite sub-band edge.

For a device or system that utilizes the asynchronous sub-band, and that can dynamically change the region of the sub-band used for its operation, the manufacturer shall declare whether such a device can also change its bandwidth dynamically. If the device does dynamically change bandwidth, the manufacturer shall provide information concerning the bandwidths used, and shall describe the bandwidth change algorithm sufficiently to facilitate testing. If such devices aggregate spectrum in units greater than 2.5 MHz, they shall be treated as wideband devices. Otherwise, they shall be treated as narrowband devices.

²⁸Refer to 47 CFR 15, Subpart D, 15.321(b).

The emission bandwidth and monitoring bandwidth measurements (see 7.4) are made under the conditions of no other interference or activity in the UPCS bands.

8.1.2 Isochronous time and spectrum window selection²⁹

8.1.2.1 Test for first free channel below lower threshold

The test for the first free channel below lower threshold shall be performed as follows:

- a) Arrange for there to be no interference or any other activity in the UPCS band in the EUT's operating environment.
- b) Verify that the EUT establishes a connection as follows:
 - For devices with an emission bandwidth less than 625 kHz, the EUT establishes a connection in a channel within the 3 MHz limit from the lower-frequency edge of the sub-band.
 - For devices with an emission bandwidth greater than 625 kHz, the EUT establishes a connection in a channel within the 3 MHz limit from the upper-frequency edge of the sub-band.
- c) Use interference with levels for the "lower threshold" test (see 7.2.4 for procedures) or frequency-administration commands to block all system-carrier frequencies that overlap the 3 MHz from the lower edge of the sub-band (for devices with an emission bandwidth less than 625 kHz) or from the upper edge of the sub-band (for devices with an emission bandwidth greater than 625 kHz). The EUT should transmit on the next available system-carrier frequency above (or below) the blocked frequencies. Widen the blocked region to all system carriers that overlap the first 4 MHz from the lower (or upper) edge of the sub-band; and the EUT should transmit on the next available system-carrier frequency.
- d) If the EUT fails any of the requirements of the previous step, it fails the test.

8.1.2.2 Tests for three-band limit

For devices that can operate in the least-interfered channel (LIC) mode, and are capable of operation on more than three different carriers in one frame and with a device or group of devices capable of operating within 1 m of each other, a test shall be performed to verify that, when operating in the LIC mode, the EUT will not occupy more than three 1.25 MHz bands. Such a test shall be performed by proceeding as follows:

- a) Force the EUT to occupy three different 1.25 MHz bands. One way to create this condition is to establish simultaneous connections between the EUT and three different companion devices, each in a different 1.25 MHz band. This can be achieved using either test commands or interference.
- b) Once the EUT is transmitting in three separate 1.25 MHz bands, force a (fourth) companion device to attempt to establish a connection in a fourth 1.25 MHz band. The companion device can be forced to do this using either interference or a test command (e.g., a command that forces the companion device to request a connection on a specified time/spectrum window).
- c) The success criterion is that the EUT will not establish a connection in a fourth 1.25 MHz band.

The following two test alternatives are examples of specific procedures for performing this test. They may need to be modified as appropriate to the channel selection and connection protocols used by the EUT. Alternative #1 (see 8.1.2.2.1) uses interference generators to create the conditions necessary for the test. While this procedure is relatively straightforward for a frequency-division multiple access (FDMA) system, it is somewhat cumbersome for a time-division multiple access (TDMA) system, because of the need to fill all time/spectrum windows except one with interference in each of three 1.25 MHz bands. This would require three separate synchronized generators, each capable of producing interference with the specific frame and slot pattern used by the EUT, in addition to an out-of-operating-region generator. For systems that have the necessary commands for testing and administration, alternative #2 (see 8.1.2.2.2) may be more practical, and is an equally valid test. If desired, the existence of the required conditions can be easily verified with a spectrum analyzer.

²⁹Refer to 47 CFR 15, Subpart D, 15.323(b).

8.1.2.2.1 Test alternative #1

- a) If the EUT is designed to operate at more than one frequency within the isochronous sub-band, use out-of-operating-region interference to restrict operation of the EUT to a single frequency channel (see 7.2.4 for procedures). The EUT should still be able to establish a connection in the target channel (see Figure 15). Some EUT may defer operation when they detect any signal within the sub-band. These devices may be tested as if the EUT were designed to operate at a (single) predetermined frequency within the sub-band (see Figure 16), provided that the necessary test conditions (described above) can be created (i.e., multiple companion devices can be forced to occupy different 1.25 MHz channels).

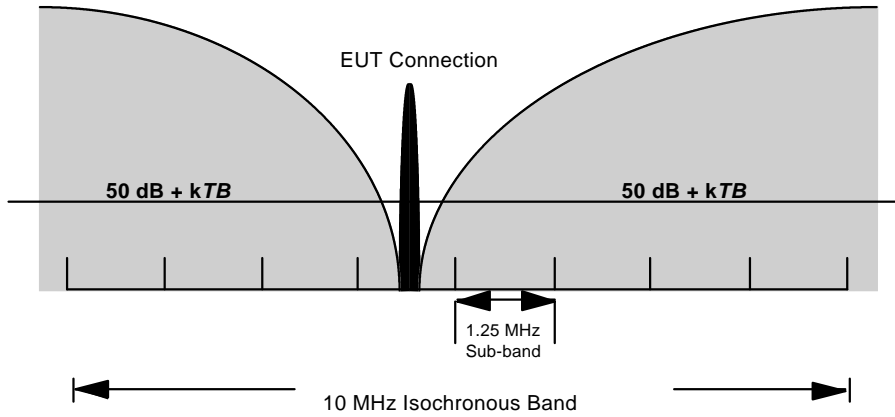

Figure 15—Illustration of how to open up a channel of an EUT that is designed to operate at more than one frequency within the 1.25 MHz channel

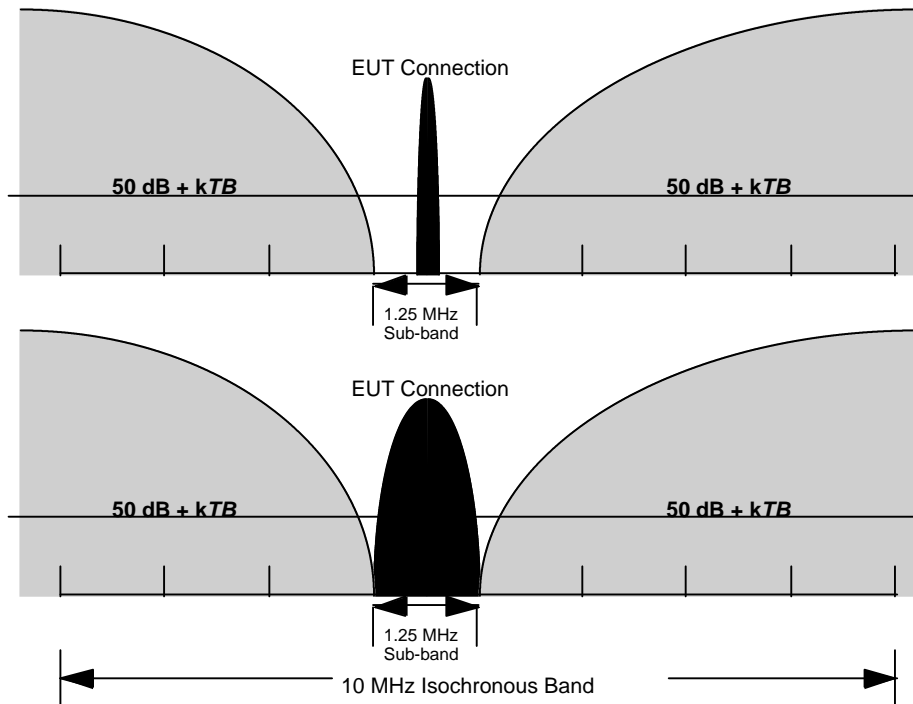

Figure 16—Illustration of how to open up a channel of an EUT that is designed to operate at a (single) predetermined frequency within the 1.25 MHz channel

- b) For devices that divide the use of the channel, in time, into a number of time slots, it is necessary to introduce pulsed synchronized interference, timed to the corresponding frame pattern of the EUT, with only one opening (duplex pair) time slot that is free of interference. The level of the interference may be set with an unmodulated signal at the upper threshold, and then the appropriate modulation may be applied (which should result in a peak envelope power that is 3 dB or more higher than the unmodulated carrier). If this is necessary, the manufacturer shall supply the necessary frame-pattern information, including the frame period and the number and duration of the (duplex pairs) time slots. An example of a possible frame pattern and the corresponding interference pattern is shown in Figure 17. Note that an interference pulse is present in all but one of the possible (duplex pairs) time slots of the frame pattern used by the EUT (see Figures 18 and 19). The EUT should still be able to establish and maintain a connection in the unblocked time slot of the frame in the selected channel of the sub-band.

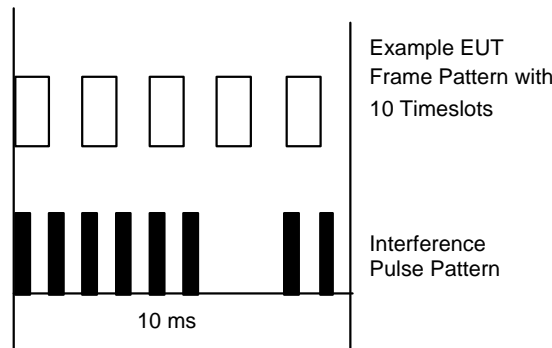

Figure 17—Example of EUT frame pattern and pulsed interference pattern for testing isochronous time and spectrum window selection

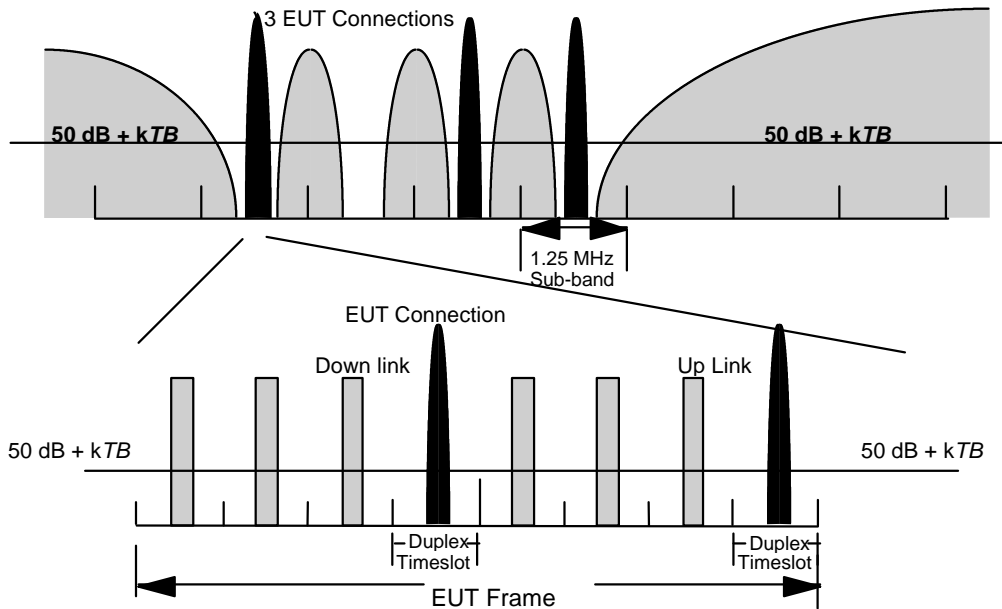

Figure 18—Illustration of how to open up one time slot within a channel of an EUT that divides the use of the channel, in time, into a number of duplex time slots

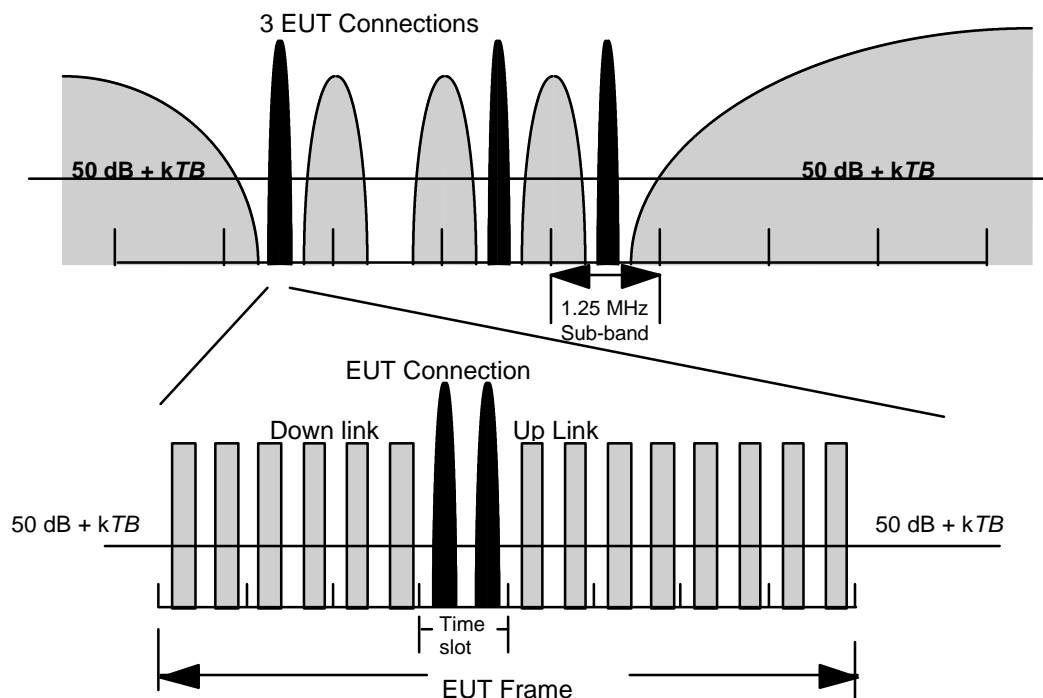

Figure 19—Illustration of how to open up one time slot within a channel of an EUT that divides the use of the channel in time into a number of interleaving duplex time slots

- c) Establish and maintain a connection with the EUT under the conditions of step b).

The following test conditions determine whether a system that is capable of operation on multiple frequencies (within a given time frame of 20 ms or less) passes or fails the three-channel maximum rule.

- d) Use a second companion device, if needed, and repeat steps a), b), and c) in a new 1.25 MHz channel.
 e) Use a third companion device, if needed, and repeat steps a), b), and c) in a new 1.25 MHz channel.
 f) Use a fourth companion device, if needed, and repeat steps a) and b) in a new 1.25 MHz channel. Verify that the EUT cannot establish a connection (see Figure 20).
 g) The EUT passes the test if it fails to establish the fourth connection.

8.1.2.2.2 Test alternative #2

Figure 21 shows the setup for this test. Any unused ports of the combiner/splitter networks shall be properly terminated.

- a) Verify that, with no interference, all four companion devices can establish simultaneous connections with the EUT.
 b) Ensure that the EUT is configured such that all carrier frequencies are allowed.
 c) Using the wideband interference generator, if necessary, to ensure LIC operation, apply interference across the entire isochronous sub-band, such that the interference received by the EUT is between the lower and upper thresholds.

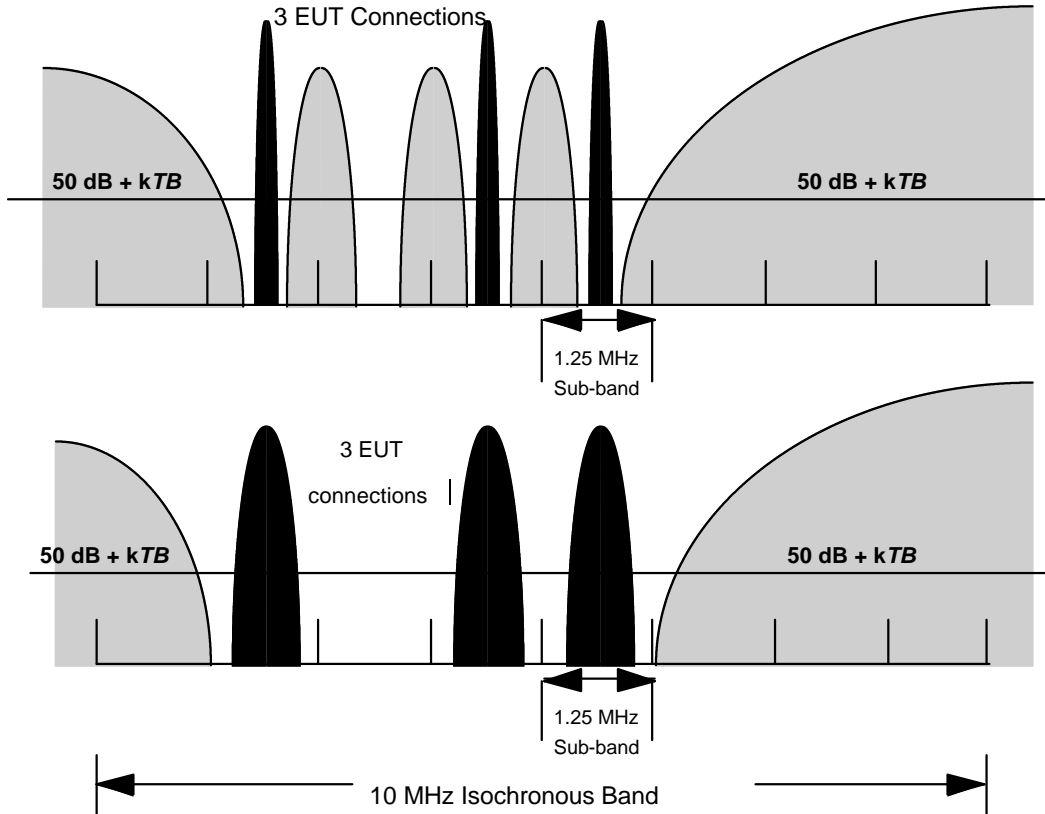

Figure 20—Illustration that EUT should only be able to make three connections over the four available channels

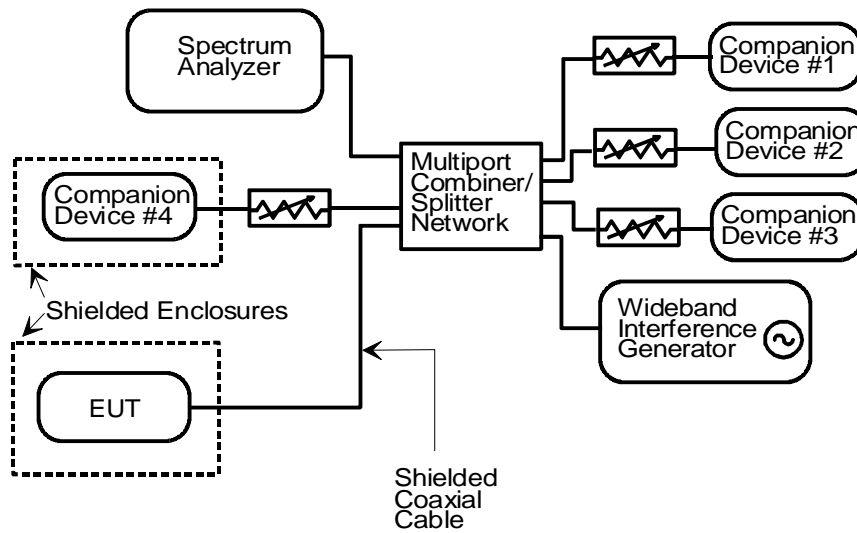

Figure 21—Setup for isochronous three-band test alternative #2

- d) Adjust the variable attenuators such that the carrier-to-interference ratio received by the EUT and all companion devices is adequate for the establishment of a reliable connection. Verify that all four companion devices can establish simultaneous connections with the EUT.
- e) Using test or administrative commands, force companion devices #1, #2, and #3 to establish connections with the EUT in the three different 1.25 MHz channels. Verify that the connections are established on the assigned frequencies.
- f) Cause companion device #4 to request a connection with the EUT in a fourth 1.25 MHz channel.
- g) If the EUT transmits or establishes a connection with companion device #4 in a fourth 1.25 MHz channel, the EUT fails the test.

8.1.3 Unacknowledged transmissions (isochronous)³⁰

This test applies to an EUT capable of transmitting control and signaling information on its own without companion devices.

- a) If the EUT is designed to operate at more than one frequency within the isochronous sub-band, use frequency-administration commands or out-of-operating-region interference (using the procedures in 7.2.4) to restrict operation of the EUT to a single frequency. Some EUT may defer operation when they detect any signal within the sub-band. These devices may be tested as if the EUT were designed to operate at a (single) predetermined frequency within the sub-band.
- b) For devices that divide the channel into a number of time slots, it is necessary to introduce pulsed synchronized interference, timed to the corresponding frame pattern of the EUT, with only one time slot free of interference. The level of the interference may be set with an unmodulated signal at the upper threshold, and then the appropriate modulation may be applied. If this is necessary, the manufacturer shall supply the necessary frame-pattern information, including the frame period and the number and duration of the (duplex pairs) time slots.
- c) Initiate transmission by the EUT. The EUT shall terminate its repetitive transmission on the open time/spectrum window within 30 s. Make note of the actual duration of the EUT transmission on the time/spectrum window.
- d) Measure the time interval between the end of the EUT transmission and the beginning of transmission by the EUT. Repeat this measurement five times. If any of the measured time intervals is less than 10 ms, the EUT fails the test. If all of the measured time intervals exceed 150 ms, the EUT passes the test. Otherwise, repeat the measurement another 95 times. If each of the time intervals measured is more than 10 ms, and the measured time intervals vary uniformly between 10 ms and 150 ms or more, the EUT passes the test.
- e) Remove all interference and, if necessary, administer the system to operate on all carrier frequencies. Apply interference at a level that is 6 dB above the measured lower threshold to all system carriers overlapping the 3 MHz nearest the preferred end of the sub-band (the lower end of the sub-band if the EUT emission bandwidth is less than 625 kHz, or the upper end of the sub-band if the EUT emission bandwidth is greater than 625 kHz). If necessary, reset the system and verify that transmission occurs on the available system-carrier frequency nearest to the blocked channels. After the 30 s transmission limit on the current time/spectrum window has expired, the EUT shall not reinitiate transmission on the same time/spectrum window, except under the provisions of step d) above. Otherwise, the EUT fails the test. If transmission continues uninterrupted, it shall continue on a different time/spectrum window (which shall also be outside the blocked frequencies).
- f) At least 10 s before the current EUT transmission interval is due to expire, remove all the interference. Verify that the next EUT transmission occurs on a system-frequency channel overlapping the 3 MHz at the preferred end of the sub-band, for devices capable of accessing this spectrum. If the EUT is not capable of accessing this spectrum, transmission shall occur on the first available system carrier adjacent to the 3 MHz at the preferred end of the band.

³⁰Refer to 47 CFR 15, Subpart D, 15.323(c)(4) and 15.323(c)(6).

8.2 Isochronous timing tests

8.2.1 Acknowledgments³¹

- a) Activate the EUT with the companion device off, and monitor the signal from the EUT on a spectrum analyzer.
- b) Verify that the EUT does not transmit on the current time/spectrum window for more than the limit (1 s if a communication channel is transmitted; 30 s if a control/signaling channel is transmitted).
- c) Activate the EUT and its companion device, and verify that communication occurs between them.
- d) Turn off the companion device, and verify that the EUT terminates its transmission on the current time/spectrum window in 30 s or less.

8.2.2 Transmission duration³²

- a) Place the EUT and its companion device in the test location.
- b) Activate the EUT and the companion device so that communication occurs between them, and start a timer or frame counter.
- c) Stop the timer at the end of the EUT transmission on the current channel.
- d) Verify that time is less than the limit. (For a device with a frame period of 10/X ms, no more than 2 880 000 X frames³³ should be transmitted without a break.)

8.2.3 Duplex connections³⁴

This test verifies that the two devices communicating over a duplex connection comply with the access criteria. It applies to devices that are designated as “initiating” and “responding” devices and, together, shall satisfy the criteria of 47 CFR 15, Subpart D, 15.323(c)(10).³⁵ The manufacturer shall state whether the criteria of 47 CFR 15, Subpart D, 15.323(c)(10), are used, and if so, which devices are initiating devices and which devices are responding devices. The manufacturer shall provide, as part of the test report, appropriate diagrams and other material to explain procedures for making duplex connections.

The EUT is the initiating device. To comply with 47 CFR 15, Subpart D, 15.323(c)(10), the EUT shall monitor both its transmit and receive time/spectrum window. The test, therefore, requires that interference at the EUT on its transmit and receive time/spectrum windows be varied independently. Figure 22 gives an illustrative example of the interference, as seen at the EUT. Figure 22(a) represents the interference pattern to a time-division multiple access (TDMA) EUT using time-division duplexing (TDD) with a single RF carrier per 1.25 MHz band, and eight duplex time slots per carrier. Figure 22(b) shows the interference to a frequency-division multiple access (FDMA) EUT using TDD with a single-duplex channel per carrier, but eight carriers per 1.25 MHz band.

Note that in both the TDMA and FDMA cases, the transmit and receive time/spectrum windows have different power levels at the EUT. Furthermore, a transmit time/spectrum window may be interference-free while its paired receive window is not. In the example shown, the power levels of the receive windows are 7 dB higher than those of the transmit windows. In each case, one transmit window and one receive window is interference-free, but the interference-free transmit and receive windows do not constitute a duplex pair. In the TDMA example, transmit slot 6 and receive slot 2 are interference-free. In the FDMA example, the transmit slot on frequency 3 and the receive slot on frequency 6 are interference-free. Production of these interference patterns requires interference generators that can be synchronized to the EUT’s frame clock, and can generate bursts of interference equal to the duration of the EUT transmit/receive bursts.

³¹Refer to 47 CFR 15, Subpart D, 15.323(c)(4).

³²Refer to 47 CFR 15, Subpart D, 15.323(c)(3).

³³ $(3600 \text{ s/h})(8 \text{ h})/(10/X \text{ ms/frame}) = 2\,880\,000$.

³⁴Refer to 47 CFR 15, Subpart D, 15.323(c)(10).

³⁵Refer to 47 CFR 15, Subpart D, 15.323(c)(10), which specifies that for the initiating device “both the intended transmit and receive time and spectrum windows [shall] meet the access criteria.” This is interpreted to mean, in the case of LIC operation per 47 CFR 15, Subpart D, 15.323(c)(5), that the greatest of the monitored levels on the transmit and receive time/spectrum windows is used to determine the least-interfered time/spectrum window duplex pair.

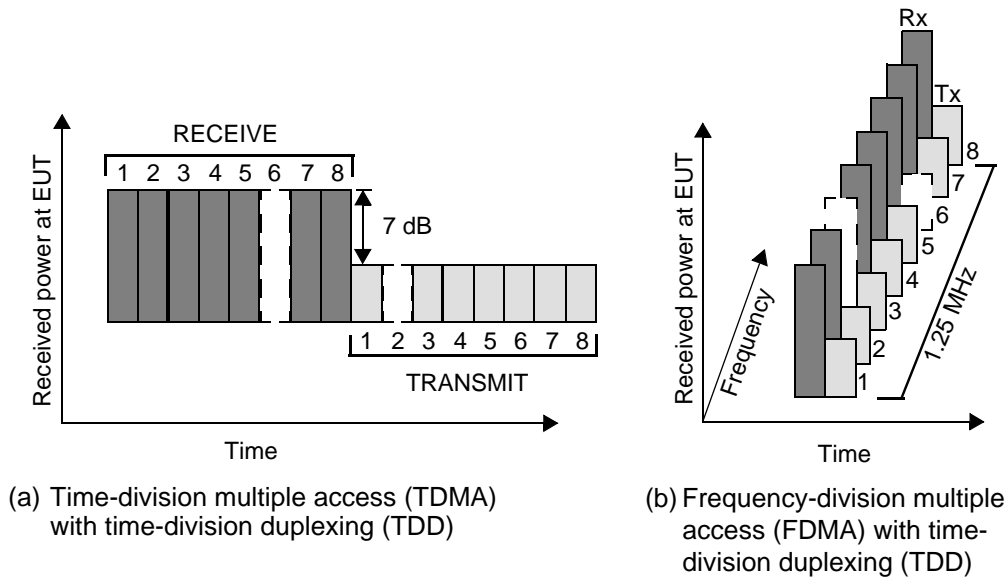

Figure 22—Examples of interference for the duplex connection test

If no system-clock signal is available to synchronize the interference generators to the system's frame timing, a connection shall be established and the start of the initiating device's transmit burst shall be used as the synchronization signal (the transceiver pair used to generate the synchronization signal shall be electromagnetically isolated from the EUT and the companion device). For an FDMA/TDD system, this procedure will provide frame synchronization. For a TDMA/TDD system, this procedure will provide slot synchronization; however, the transmit burst can occur on any slot in the transmit portion of the initiating device's frame. Thus, it is possible that both interference-free slots from the generators could occur in either the transmit or receive portion of the EUT's frame. However, the steps below still apply because the initiating device shall monitor both transmit and receive time/spectrum windows. The success criterion still is that the duplex slot pair is selected on which the interference power on the "interfered" half of the connection (transmit or receive) is either below the lower threshold or is at a minimum (if interference is above the lower threshold on all pairs). For example, in Figure 22, the slot pair labeled "6" should be selected.

The same approach can be applied to systems that use frequency duplexing.³⁶ For completeness, Figure 23 gives an illustrative example of the interference for an FDMA system using frequency duplexing.

In any of the steps below, if the EUT fails to transmit when it should (according to the manufacturer's declared thresholds and operating protocols), any necessary adjustments shall be made in the path loss between the EUT, the companion device, and the out-of-operating-region interference, and the step shall be repeated.

- a) This test will be performed on each type of initiating device with each type of responding device.
- b) Adjust the path loss between the EUT and its companion device such that the received signal to the EUT from the companion device is at least 40 dB above the lower threshold.

³⁶It is expected that most systems in the 1920–1930 MHz band will use TDD because of the need for frequency-duplexed systems to maintain some frequency separation between the transmit and receive bands. Moreover, the application of the "packing" rules in 47 CFR 15, Subpart D, 15.323(b), to frequency-duplexed systems, which would likely use both ends of the 1920–1930 MHz band simultaneously, is unclear. Finally, the requirement that a device monitor its own transmit time/spectrum window would tend to make implementation of a frequency-duplexed system awkward.

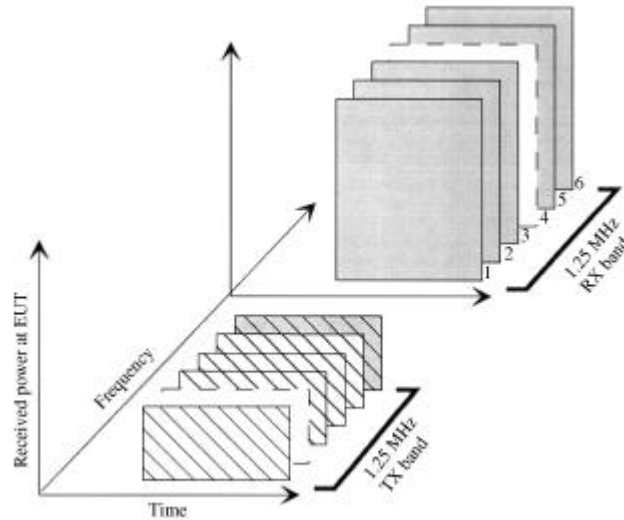

Figure 23—Example of duplex interference for FDMA frequency-duplexed system

- c) By using either frequency-administration commands or out-of-operating-region interference, restrict the EUT and its companion device to operation within a single 1.25 MHz band. If out-of-operating-region interference is used to confine the EUT to the band, use the procedures of 7.2.4 to ensure that the out-of-operating-region interference does not corrupt the test results. Verify that the EUT and its companion device can establish a connection on a time/spectrum window in the designated 1.25 MHz band. If not, adjust the path loss so that a connection can be established. Terminate the connection.
- d) Apply interference at the calculated lower threshold limit to the EUT on all of its receive time/spectrum windows in the 1.25 MHz band except one, which shall remain free of interference. Apply interference at the calculated lower threshold limit to the EUT on all transmit time/spectrum windows within the 1.25 MHz band. Ensure that the interference levels at the companion device are at least 10 dB below the measured lower threshold for all time/spectrum windows.
- e) Cause the EUT to attempt to establish a connection. If a connection is established and the system has less than 40 channels, the test is failed.
- f) If a connection exists, terminate it. Apply interference at the calculated lower-threshold limit to the EUT on all of its transmit time/spectrum windows in the 1.25 MHz channel except one, which shall remain free of interference. Apply interference at the calculated lower-threshold limit to the EUT on all receive time/spectrum windows. Ensure that the interference levels at the companion device are at least 10 dB below the measured lower threshold for all time/spectrum windows.
- g) Cause the EUT to attempt to establish a connection. If a connection is established and the system has less than 40 channels, the test is failed.
- h) If a connection exists, terminate it. Apply interference to the EUT on the EUT's transmit time/spectrum windows at a level that is 3 dB above the measured lower threshold on all time/spectrum windows except for one. Adjust the interference to the EUT on its receive time/spectrum windows such that a single time/spectrum window is interference-free, and the interference on the other time/spectrum windows is 10 dB above the measured lower threshold. The interference to the companion device should be at least 10 dB below the lower threshold on all active time/spectrum windows. The interference-free receive time/spectrum window shall not be the duplex mate of the interference-free transmit time/spectrum window.³⁷ This is the specific case shown in Figure 22.
- i) Cause the EUT to attempt to establish a connection. The connection should be made on the interference-free receive time/spectrum window and its duplex mate. Otherwise, the system fails the test.

³⁷This assumes that the system designates a fixed duplex pairing for transmit and receive time/spectrum windows. If this is not the case, the interference-free time/spectrum windows shall be selected by the EUT for both the transmit and receive directions.

- j) If a connection exists, terminate it. Reduce the interference on the EUT's receive time/spectrum windows to a level that is 3 dB above the measured lower threshold, maintaining one time/spectrum window that is interference-free. Raise the interference on the EUT's transmit time/spectrum windows to a level 10 dB above the measured lower threshold, maintaining one time/spectrum window that is interference-free. The interference to the companion device should be at least 10 dB below the measured lower threshold on all active time/spectrum windows. Again, the interference-free transmit and receive time/spectrum windows should not constitute a duplex pair, if the system designates a specific duplex pairing for time/spectrum windows.
- k) Cause the EUT to attempt to establish a connection. The connection should be made on the interference-free transmit time/spectrum window and its duplex mate. Otherwise, the system fails the test.
- l) Terminate the connection and raise the interference to the EUT on all of the EUT's transmit and receive time/spectrum windows to the calculated upper threshold limit, except for a single transmit time/spectrum window and a single receive time/spectrum window, which shall remain interference-free. The interference-free transmit and receive time/spectrum windows shall not constitute a duplex pair. Adjust the path loss between the EUT and its companion device such that the received signal to the EUT from the companion device is at least 30 dB above the upper threshold. Cause the EUT to attempt to establish a connection. If the EUT transmits (attempts to establish a connection), or a connection is established, the test is failed.

8.2.4 Alternative monitoring interval³⁸

The manufacturer shall state whether the system uses the provisions of 47 CFR 15, Subpart D, 15.323(c)(10) and 15.323(c)(11), and, if so, which devices are the "initiating devices" and which devices use the provisions of 47 CFR 15, Subpart D, 15.323(c)(11). The manufacturer shall provide, in the test report, the appropriate diagrams and other material to explain the use of the provisions of 47 CFR 15, Subpart D, 15.323(c)(11). This test will be performed on each type of initiating device that uses the provisions of 47 CFR 15, Subpart D, 15.323(c)(11). The EUT is the initiating device. The companion device is the responding device. Each type of initiating device shall be tested with each type of responding device.

- a) Adjust the path loss between the EUT and its companion device such that the received signal to the EUT from the companion device is at least 30 dB above the measured lower threshold.
- b) By using either frequency-administration commands or out-of-operating-region interference, restrict both the EUT and its companion device to operation on a single 1.25 MHz band. If out-of-operating-region interference is used to confine the EUT to the band, use the procedures of 7.2.4 to ensure that the residual interference power from the out-of-operating-region interference generator(s) does not corrupt the test results. Verify that the EUT and its companion device can establish a connection. If not, adjust the out-of-operating-region interference (if used) so that a connection can be established.
- c) Apply interference at the measured lower threshold to the EUT on all transmit time/spectrum windows in the selected 1.25 MHz band. The interference shall use the same physical-layer parameters (modulation, frame format, etc.) as the EUT transmissions, but with a system identifier that is different from that used by the EUT and the companion device.³⁹ Ensure that the interference level at the companion device is at least 10 dB below the measured lower threshold. Apply no interference to the receive time/spectrum windows in the 1.25 MHz band.
- d) Cause the EUT to attempt to establish a connection. If a connection is established and the device has less than 40 channels, the test is failed.
- e) If a connection exists, terminate it. Raise the interference to the EUT in all of the transmit time/spectrum windows to the measured upper threshold. Ensure that the interference level at the companion device is at least 10 dB below the upper threshold. Again, apply no interference to the receive time/spectrum windows in the selected 1.25 MHz band.
- f) Adjust the path loss between the EUT and its companion device such that the received signal to the EUT is at least 30 dB above the interference.
- g) Cause the EUT to attempt to establish a connection. If a connection is established, the test is failed.

³⁸Refer to 47 CFR 15, Subpart D, 15.323(c)(11).

³⁹This is to test the ability of the EUT to distinguish between same-system and other-system interference for purposes of satisfying the requirement of 47 CFR 15, Subpart D, 15.323(c)(11).

9. Test report

Test reports are the means for presenting the test results to the appropriate procuring or regulatory agency or for archiving the data in the permanent files of the testing organization. As such, test reports shall be written in clear, unambiguous language.

9.1 Test report contents

The conditions of test listed in the following subclauses shall be described in the test report in order for the test results to be documented properly.

9.2 Applicable standards

In addition to this standard, any standards to which the EUT was tested shall be described clearly in the test report. Where referenced standards have more than one measurement procedure, or where the referenced measurement procedure has options, the test report shall state which procedures or options were used. The test report shall also state the issue or year of the referenced standard or standards used.

9.3 Equipment units tested

The test report shall list all equipment tested, including product type and marketing designations, where applicable. Serial numbers and any other distinguishing identification features shall also be included in the test report. Identification or detailed description shall also be made of interconnecting cables. The rationale for selecting the EUT (comprised of the equipment units needed to be functionally complete as well as the necessary cabling) shall be noted in the test report.

9.4 Test configuration

The setups of the equipment and cable or wire placement on the test site that produce the highest radiated emissions and the highest ac power line conducted emissions shall be clearly shown and described. Drawings or photographs may be used for this purpose. A block diagram showing the interconnection of the major functional units is also useful.

9.5 List of test equipment

A complete list of all test equipment used shall be included with the test report. Manufacturer's model and serial numbers and the date of the last calibration and calibration interval shall be included. Measurement cable loss, measuring instrument bandwidth and detector function, video bandwidth, if appropriate, and antenna factors shall also be included, where applicable.

9.6 Units of measurement

Measurements of conducted emissions shall be reported in units of dB referenced to 1 mW (dBm). Measurements of operating frequency, operating frequency with variations in ambient temperature and input voltage, and occupied bandwidth of intentional radiators shall be reported in units of Hz or multiples thereof (e.g., kHz, MHz, etc.). Measurements of input power to intentional radiators shall be reported in units of W. All formulas of conversions and conversion factors, if used, shall be included in the measurement report.

9.7 Location of test site

The location of the test site shall be identified in the test report. Sites that have received recognition from various accreditation bodies shall use the same site address information as was included in their original application for recognition.

9.8 Measurement procedures

The sequence of testing that was followed in order to determine the data included in the test report should be documented.

9.9 Reporting measurement data

The measurement results, along with the appropriate limits for comparison, shall be presented in tabular or graphical form. Alternatively, recorded charts or photographs of a spectrum-analyzer display or other self-displaying instrumentation may be used if the information is presented in a manner that clearly shows a comparison to the limits and explains all data conversion. The method of comparing measured data output to the limits shall be included.

9.10 General and special conditions

If an alternate test method was used, the test report shall identify and describe that method, provide justification for its use, and describe how the results obtained through its use correlate with the methods specified by the standard to which the EUT was tested. Instrumentation, instrument attenuator and bandwidth settings, detector function, EUT arrangement, and all other pertinent details of the test shall be provided so that the alternate test method can be replicated. Where automatic scan techniques were used, an explanation of how the highest emission, relative to the limit from the EUT, was determined and the scan rate used to obtain recorded emissions are to be included in the test report. The actual operating and environmental conditions (e.g., voltage, power-line frequency, temperature, relative humidity, etc.) shall be listed in the report.

9.11 Summary of results

The test report summary section shall indicate whether the EUT passes or fails, and shall give margins (where applicable) with respect to the limits to which it was tested. If the equipment only passes with specific modifications or special attributes (such as shielded cables), this information shall be included in the summary results.

9.12 Required signatures

The test report shall contain the signature of the representative of the organization that is performing the tests. In addition, the test report shall contain the identification of the staff who were responsible for the proper execution of the test, and the name and address of the party requesting the tests. If changes are made during the period of test to bring the EUT into compliance, the test report shall indicate these changes. In addition, the report submitted to the procuring organization or regulatory agency shall include a signed statement by the manufacturer or developer agreeing to the changes and their incorporation into production.

9.13 Test report appendixes

The test report shall contain, if required, photographs or detailed sketches of the EUT configuration that show sufficient information to allow the EUT to be reconfigured in a manner that would allow the original test to be replicated with a high likelihood that the test results would be in agreement with the results of the original test, within acceptable tolerances.

9.14 Test report disposition

The test report shall be maintained by the testing organization for a period of at least three years following the date of the test. The manufacturer may be required by a regulatory agency to maintain a copy of the report for a longer period of time.

Annex A

(informative)

47 CFR 15, Subpart D—Rules and test cases for unlicensed PCS

Part 15 D - Unlicensed PCS Devices, November 1994		ANSI test
Scope	15.301 This subpart sets out the regulations for unlicensed personal communications services (PCS) devices operating in the 1910–1930 MHz frequency band.	Information
Definitions	15.303	
Asynchronous devices	15.303a asynchronous devices: Devices that transmit RF energy at irregular time intervals, as typified by local area network data systems.	Definition
Coordinatable PCS device	15.303b coordinatable PCS device: PCS devices whose geographical area of operation is sufficiently controlled, either by necessity of operation with a fixed infrastructure or by disabling mechanisms, to allow adequate coordination of their locations relative to incumbent fixed-microwave facilities.	Definition
Emission bandwidth	15.303c emission bandwidth: For purposes of this subpart, the emission bandwidth shall be determined by measuring the width of the signal between two points, one below the carrier center frequency and one above the carrier center frequency, that are 26 dB down relative to the maximum level of the modulated carrier. Compliance with the emissions limits is based on the use of measurement instrumentation that employs a peak detector function with an instrument resolutions bandwidth approximately equal to 1% of the emission bandwidth of the device under measurement.	Subclause 6.1.3
Isochronous devices	15.303d isochronous devices: Devices that transmit at a regular interval, typified by time-division voice systems.	Definition
Noncoordinatable PCS device	15.303e noncoordinatable PCS device: A PCS device that is capable of randomly roaming and operating in geographic areas containing incumbent microwave facilities such that operation of the PCS device will potentially cause harmful interference to the incumbent microwave facilities.	Definition
Peak transmit power	15.303f peak transmit power: The peak power output as measured over an interval of time equal to the frame rate or transmission burst of the device under all conditions of modulation. Usually, this parameter is measured as a conducted emission by direct connection of a calibrated test instrument to the equipment under test. If the device cannot be connected directly, alternative techniques acceptable to the Commission may be used.	Subclause 6.1.2

PCS devices	15.303g personal communications service (PCS) devices [unlicensed]: Intentional radiators operating in the frequency band of 1910–1930 MHz that provide a wide array of mobile and ancillary fixed communication services to individuals and businesses.	Definition
Spectrum window	15.303h spectrum window: An amount of spectrum equal to the intended emission bandwidth in which operation is desired.	Definition
Sub-band	15.303i sub-band: For purposes of this subpart, the term sub-band refers to the spectrum allocated for isochronous or asynchronous transmission.	Definition
Thermal noise power	15.303j thermal noise power: The noise power, in W, defined by the formula $N = kTB$ where N is the noise power, in W, k is Boltzmann's constant, T is the absolute temperature, in degrees kelvin (e.g., 295 °K), and B is the emission bandwidth of the device, in Hz.	Definition
Time window	15.303k time window: An interval of time in which transmission is desired.	Definition
Equipment authorization	15.305 Equipment authorization requirement. PCS devices operating under this subpart shall be certificated by the Commission under the procedures in Subpart J of Part 2 of this Chapter before marketing. The application for certification shall contain sufficient information to demonstrate compliance with the requirements of this subpart.	Information
Coordination	15.307 Coordination with fixed microwave service.	UTAM test
UTAM role	15.307a UTAM, Inc., is designated to coordinate and manage the transition of the 1910–1930 MHz band from private operational-fixed microwave service (OFS) operating under Part 94 of this Chapter to unlicensed PCS operations, conditioned upon submittal to and acceptance by the Commission of: (1) a funding plan that is equitable to all prospective manufacturers of unlicensed PCS devices; and (2) a plan for “band clearing” that will permit the implementation of noncoordinatable (nomadic) devices and, in particular, noncoordinatable data PCS devices, as promptly as possible. The responsibilities of UTAM, Inc., include, but are not limited to, relocation of existing OFS microwave stations pursuant to requirements established in ET Docket No. 92-9, negotiating costs of relocation, ensuring that comparable facilities are provided, and resolving any disputes of interference to OFS microwave operations from unlicensed PCS operations. These responsibilities shall terminate upon a determination by the Commission that interference to OFS microwave operations from unlicensed PCS operations is no longer a concern.	UTAM test
UTAM certification	15.307b Each application for certification of equipment operating under the provisions of this Subpart shall be accompanied by an affidavit from UTAM, Inc., certifying that the applicant is a participating member of UTAM, Inc. In the event that a grantee fails to fulfill the obligations attendant to participation in UTAM, Inc., the Commission may invoke administrative sanctions, as necessary, to preclude continued marketing and installation of devices covered by the grant of certification, including but not limited to revoking certification.	UTAM test

Noncoordinatable PCS devices	15.307c An application for certification of a PCS device that is deemed by UTAM, Inc., to be noncoordinatable will not be accepted until the Commission announces that a need for coordination no longer exists.	UTAM test
Coordinatable PCS devices	15.307d A coordinatable PCS device is required to incorporate means that ensure that it cannot be activated until its location has been coordinated by UTAM, Inc. The application for certification shall contain an explanation of all measures taken to prevent unauthorized operation. This explanation shall include all procedural safeguards, such as the mandatory use of licensed technicians to install the equipment, and a complete description of all technical features controlling activation of the device.	UTAM test
Disabling automatic mechanism	15.307e A coordinatable PCS device shall incorporate an automatic mechanism for disabling operation in the event that it is moved outside the geographic area where its operation has been coordinated by UTAM, Inc. The application for certification shall contain a full description of the safeguards against unauthorized relocation and shall satisfy the Commission's requirement that the safeguards cannot be easily defeated.	UTAM test
Disabling mechanism requirement	15.307f At such time as the Commission deems that the need for coordination between unlicensed PCS operations and existing Part 94 private operational-fixed microwave services ceases to exist, the disabling mechanism required by paragraph (e) will no longer be required.	UTAM test
Coordination time period	15.307g Operations under the provisions of this subpart are required to protect systems in the private operational-fixed microwave service operating within the 1850–1990 MHz band until the dates and conditions specified in Section 94.59 of this Chapter for termination of primary status are met. Interference protection is not required for Part 94 stations in this band that are licensed on a secondary basis.	UTAM test
Relocation	15.307h The operator of a PCS device that is relocated from the coordinated area specified by UTAM, Inc., shall cease operating the device until coordination for the new location is verified by UTAM, Inc.	UTAM test
Cross references	15.309 Cross references.	
	15.309a The provisions of Subpart A of this Part apply to unlicensed PCS devices, except where specific provisions are contained in Subpart D.	Subclause 6.1.6
	15.309b The requirements of Subpart D apply only to the radio transmitter contained in the PCS device. Other aspects of the operation of a PCS device may be subject to requirements contained elsewhere in this Chapter. In particular, a PCS device that includes digital circuitry that is not directly associated with the radio transmitter also is subject to the requirements for unintentional radiators in Subpart B.	Subclause 6.1.6

Labeling	15.311 In addition to the labeling requirements of Section 15.19(a)(3), all devices authorized under this subpart shall bear a prominently located label with the following statement: Installation of this equipment is subject to notification and coordination with UTAM, Inc. Any relocation of this equipment shall be coordinated through, and approved by UTAM. UTAM may be contacted at [insert UTAM's toll-free number].	Labels
Measurement procedures	15.313 Measurement procedures. Measurements shall be made in accordance with Subpart A, except where specific procedures are specified in Subpart D. If no guidance is provided, the measurement procedure shall be in accordance with good engineering practice.	ANSI C63.17-1997 (general)
Conducted limits	15.315 Conducted limits. An unlicensed PCS device that is designed to be connected to the public utility (ac) power line shall meet the limits specified in Section 15.207.	ANSI C63.4-1992
Antenna requirement	15.317 Antenna requirement. An unlicensed PCS device shall meet the antenna requirement of Section 15.203.	Information
General technical requirements	15.319 General technical requirements.	
Frequency of operation	15.319a The 1910–1920 MHz sub-band is limited to use by asynchronous devices under the requirements of Section 15.321. The 1920–1930 MHz sub-band is limited to use by isochronous devices under the requirements of Section 15.323.	Information
Digital modulation	15.319b All transmissions shall use only digital modulation techniques.	Subclause 6.1.4
Peak transmit power	15.319c Peak transmit power shall not exceed 100 μ W multiplied by the square root of the emission bandwidth, in Hz. Peak transmit power shall be measured over any interval of continuous transmission using instrumentation that is calibrated in terms of an rms-equivalent voltage. The measurement results shall be properly adjusted for any instrument limitations, such as detector response times, limited RBW capability when compared to the emission bandwidth, sensitivity, etc., so as to obtain a true peak measurement for the emission in question over the full bandwidth of the channel.	Subclause 6.1.2
Power spectral density	15.319d Power spectral density shall not exceed 3 mW in any 3 kHz bandwidth, as measured with a spectrum analyzer having a RBW of 3 kHz.	Subclause 6.1.5

Antenna gain	15.319e The peak transmit power shall be reduced by an amount, in dB, such that the maximum directional gain of the antenna exceeds 3 dBi.	Clause 4
Operational failure requirement	15.319f The device shall automatically discontinue transmission in case of either absence of information to transmit or operational failure. These provisions are not intended to preclude transmission of control and signaling information or use of repetitive codes used by certain digital technologies to complete frame or burst intervals.	Declaration
Spurious emission	15.319g Notwithstanding other technical requirements specified in this subpart, attenuation of emissions below the general emission limits in Section 15.209 is not required.	Subclause 6.1.6
Spurious emission transition limits	15.319h Where there is a transition between limits, the tighter limit shall apply at the transition point.	Information
Safety exposure levels	15.319i The device shall comply with IEEE C95.1-1991, Safety Levels with Respect to Human Exposure to Radio Frequency Electromagnetic Fields, 3 kHz to 300 GHz. Measurement methods are specified in IEEE C95.3-1991, IEEE Recommended Practice for the Measurement of Potentially Hazardous Electromagnetic Fields—RF and Microwave. Copies of these standards are available from the Institute of Electrical and Electronics Engineers, 445 Hoes Lane, P.O. Box 1331, Piscataway, NJ 08855-1331, USA, telephone 1-800-678-4333. All equipment shall be considered to operate in an “uncontrolled” environment. The application for certification shall contain a statement confirming compliance with IEEE C95.1-1991. Technical information showing the basis for this statement shall be submitted to the Commission upon request. PCS hand-held devices whose radiated power is 100 mW or less are excluded from SAR testing requirements as long as a 25 mm separation is maintained between the radiating structure and the body of the user. The IEEE standards use the term “radiated power” as meaning the input power to the antenna.	Refer to IEEE C95.1-1991
Isochronous device	15.323 Specific requirements for isochronous devices operating in the 1920–1930 MHz sub-band.	
Channel allocation	15.323a Operation shall be contained within one of eight 1.25 MHz channels starting with 1920–1921.25 MHz and ending with 1928.75–1930 MHz. Further subdivision of a 1.25 MHz channel is permitted with a reduced power level, as specified in Section 15.319(c). In no event, however, shall the emission bandwidth be less than 50 kHz.	Statement of channel planning
Channel packing	15.323b Intentional radiators with an intended emission bandwidth of less than 625 kHz shall start searching for an available time and spectrum window within 3 MHz of the sub-band edge at 1920 MHz, and shall search upward from that point. Devices with an intended emission bandwidth greater than 625 kHz shall start searching for an available time and spectrum window within 3 MHz of the sub-band edge at 1930 MHz, and shall search downward from that point.	Subclause 8.1.2

Listen before transmit (LBT)	15.323c An isochronous device shall incorporate a mechanism for monitoring the time and spectrum windows that its transmission is intended to occupy. The following criteria shall be met:	
Monitoring time	15.323c.1 Immediately prior to initiating transmission, devices shall monitor the combined time and spectrum windows in which they intend to transmit for a period of at least 10 ms, for systems designed to use a 10 ms or shorter frame period, or at least 20 ms, for systems designed to use a 20 ms frame period.	Subclause 7.5
Monitoring threshold	15.323c.2 The monitoring threshold shall not be more than 30 dB above the thermal noise power for a bandwidth equivalent to the emission bandwidth of the device.	Subclause 7.3.2.1
Maximum transmit period (≤ 8 h)	15.323c.3 If no signal above the threshold level is detected, transmission may commence and continue with the same emission bandwidth in the monitored time and spectrum windows without further monitoring. However, occupation of the same combined time and spectrum windows by a device or group of cooperating devices continuously over a period of time longer than 8 h is not permitted without repeating the access criteria.	Declaration
System acknowledgment	15.323c.4 Once access to specific combined time and spectrum windows is obtained, an acknowledgment from a system participant shall be received by the initiating transmitter within 1 s, or transmission shall cease. Periodic acknowledgments shall be received at least every 30 s, or transmission shall cease. Channels used exclusively for control and signaling information may transmit continuously for 30 s without receiving an acknowledgment, at which time the access criteria shall be repeated.	Subclause 8.2.1
Best channel	15.323c.5	
Best channel selection	15.323c.5.1 If access to spectrum is not available as determined by the above subpart, and a minimum of 40 duplex system-access channels are defined for the system, the time and spectrum windows with the lowest power level below a monitoring threshold of 50 dB above the thermal noise power determined for the emission bandwidth may be accessed.	Subclause 8.2.1
Best channel confirmation	15.323c.5.2 A device utilizing the provisions of this paragraph shall have monitored all access channels defined for its system within the last 10 s and shall verify, within the 20 ms (40 ms for devices designed to use a 20 ms frame period) immediately preceding actual channel access, that the detected power of the selected time and spectrum windows is no higher than the previously detected value.	Subclause 7.3.2.1
Power measurement resolution	15.323c.5.3 The power measurement resolution for this comparison shall be accurate to within 6 dB.	Subclause 7.3.2.1
Segment occupancy	15.323c.5.4 No device or group of cooperating devices located within 1 m of each other shall occupy more than three 1.25 MHz channels. Devices in an operational state that are utilizing the provision of this section are not required to use the search provisions of 15.323b.	Declaration

Random waiting	15.323c.6 If the selected combined time and spectrum windows are unavailable, the device may either monitor and select different windows or seek to use the same windows after waiting an amount of time that is randomly chosen from a uniform random distribution between 10–150 ms, and that commences when the channel becomes available.	Subclause 8.1.3
Monitoring requirements	15.323c.7	
Monitoring bandwidth	15.323c.7.1 The monitoring-system bandwidth shall be equal to or greater than the emission bandwidth of the intended transmission.	Subclause 7.4
Monitoring reaction time	15.323c.7.2 The monitoring system shall have a maximum reaction time less than $50 \times \sqrt{1.25/\text{emission bandwidth, in MHz}} \mu\text{s}$ for signals at the applicable threshold level, but shall not be required to be less than 50 μs . If a signal is detected that is 6 dB or more above the threshold level, the maximum reaction time shall be $35 \times \sqrt{1.25/\text{emission bandwidth, in MHz}} \mu\text{s}$, but shall not be required to be less than 35 μs .	Subclause 7.5
Monitoring antenna	15.323c.8 The monitoring system shall use the same antenna that is used for transmission, or an antenna that yields equivalent reception at that location.	Clause 4
Monitoring threshold relaxation	15.323c.9 Devices that have a power output that is lower than the maximum permitted under the rules may increase their monitoring detection threshold by 1 dB for each 1 dB that the transmitter power is below the maximum permitted.	Clause 4
Duplex system LBT	15.323c.10 An initiating device may attempt to establish a duplex connection by monitoring both its intended transmit and receive time and spectrum windows. If both the intended transmit and receive time and spectrum windows meet the access criteria, then the initiating device can initiate a transmission in the intended transmit time and spectrum window. If the power detected by the responding device can be decoded as a duplex connection signal from the initiating device, then the responding device may immediately begin transmitting on the receive time and spectrum window that is monitored by the initiating device.	Subclause 8.2.3
Co-located device LBT	15.323c.11 An initiating device that is prevented from monitoring during its intended transmit window, due to monitoring system blocking from the transmissions of a co-located (within 1 m) transmitter of the same system, may monitor the portions of the time and spectrum windows in which they intend to receive over a period of at least 10 ms. The monitored time and spectrum window shall total at least 50% of the 10 ms frame interval, and the monitored spectrum shall be within the 1.25 MHz frequency channel(s) already occupied by that device or the co-located cooperating devices. If the access criteria is met for the intended receive time and spectrum window under the above conditions, then transmission in the intended transmit window by the initiating device may commence.	Subclause 8.2.4
Fair access	15.323c.12 The provisions of (c)(10) or (c)(11) shall not be used to extend the range of spectrum occupied over space or time for the purpose of denying fair access to spectrum to other devices.	Information

Adjacent emissions	15.323d	
Adjacent channel emissions	15.323d.1 Emissions shall be attenuated below a reference power of 112 mW as follows: 30 dB between the channel edges and 1.25 MHz above or below the channel; 50 dB between 1.25–2.5 MHz above or below the channel; and 60 dB at 2.5 MHz or greater above or below the channel.	Subclause 6.1.6
Adjacent subchannel emissions	15.323d.2 Systems that further subdivide a 1.25 MHz channel into X subchannels shall comply with the following emission mask: In the bands between $1B$ and $2B$, measured from the center of the emission bandwidth, the total power emitted by the device shall be at least 30 dB below the transmit power permitted for that device. In the bands between $2B$ and $3B$, measured from the center of the emission bandwidth, the total power emitted by an intentional radiator shall be at least 50 dB below the transmit power permitted for that radiator. In the bands between $3B$ and the 1.25 MHz channel edge, the total power emitted by an intentional radiator in the measurement bandwidth shall be at least 60 dB below the transmit power permitted for that radiator.	Subclause 6.1.6
Definition	15.323d.3 B is defined as the emission bandwidth of the device, in Hz.	Information
Measurement requirement	15.323d.4 Compliance with the emission limits is based on the use of measurement instrumentation that employs a peak detector function with an instrument RBW approximately equal to 1% of the emission bandwidth of the device under measurement.	Information
Frame requirement	15.323e	
Frame period	15.323e.1 The frame period (a set of consecutive time slots in which the position of each time slot can be identified by reference to a synchronizing source) of an intentional radiator operating in these sub-bands shall be 20 ms or 10 ms/ X , where X is a positive whole number.	Subclause 6.2.4
Frame repetition stability (≤ 50 ppm)	15.323e.2 Each device that implements time division for the purpose of maintaining a duplex connection on a given frequency carrier shall maintain a frame-repetition rate with a frequency stability of at least 50 ppm.	Subclause 6.2.3
TDMA repetition stability	15.323e.3 Each device that further divides access, in time, in order to support multiple communication links on a given frequency carrier shall maintain a frame-repetition rate with a frequency stability of at least 10 ppm.	Subclause 6.2.3
Jitter (≤ 25 μ s)	15.323e.4 The jitter (time-related, abrupt, spurious variations in the duration of the frame interval) introduced at the two ends of such a communication link shall not exceed 25 μ s for any two consecutive transmissions.	Subclause 6.2.4
Continuous transmit during frame	15.323e.5 Transmissions shall be continuous in every time and spectrum window during the frame period defined for the device.	Subclause 6.2.4
Carrier stability	15.323f	

Carrier frequency stability (< 10 ppm)	15.323f.1 The frequency stability of the carrier frequency of the intentional radiator shall be maintained within ± 10 ppm over 1 h or over the interval between channel-access monitoring, whichever is shorter.	Subclause 6.2.2
Carrier frequency stability (extreme conditions)	15.323f.2 The frequency stability shall be maintained over a temperature variation of -20 °C to $+50$ °C at normal supply voltage, and over a variation in the primary supply voltage of 85–115% of the rated supply voltage at a temperature of 20 °C.	Subclause 6.2.2
Carrier frequency stability (battery)	15.323f.3 For equipment that is capable only of operating from a battery, the frequency-stability tests shall be performed using a new battery without any further requirement to vary supply voltage.	Subclause 6.2.2
Asynchronous device	15.321 Specific requirements for asynchronous devices operating in the 1910–1920 MHz sub-band.	
Channel allocation	15.321a Operation shall be contained within the 1910–1920 MHz sub-band. The emission bandwidth of any intentional radiator operating in this sub-band shall be no less than 500 kHz.	Statement of channel planning
Time and spectrum window selection	15.321b All systems of less than 2.5 MHz emission bandwidth shall start searching for an available spectrum window within 3 MHz of the sub-band edge at either 1910 MHz or 1920 MHz, while systems of more than 2.5 MHz emission bandwidth will first occupy the center half of the sub-band. Devices with an emission bandwidth of less than 1 MHz may not occupy the center half of the sub-band if other spectrum is available.	Subclause 8.1.1
Listen before transmit	15.321c An asynchronous device shall incorporate a mechanism for monitoring the spectrum that its transmission is intended to occupy. The following criteria shall be met:	
Monitoring time	15.321c.1 Immediately prior to initiating a transmission, devices shall monitor the spectrum window they intend to use for at least 50 μ s.	Subclause 7.6
Monitoring threshold	15.321c.2 The monitoring threshold shall not be more than 32 dB above the thermal noise power for a bandwidth equivalent to the emission bandwidth of the device.	Subclause 7.3.1
Transmit criteria	15.321c.3 If no signal above the threshold level is detected, a transmission burst may commence in the monitored spectrum window. Once a transmission burst has started, an individual device or a group of cooperating devices is not required to monitor the spectrum window, provided that the intraburst gap timing requirement specified below is not exceeded.	Subclause 7.6

Random waiting	15.321c.4 After completion of a transmission, an individual device or cooperating group of devices shall cease transmission and wait a deference time randomly chosen from a uniform random distribution ranging from 50–750 μ s, after which time an attempt to access the band again may be initiated. For each occasion that an access attempt fails after the initial interburst interval, the range of the deference time chosen shall double, until an upper limit of 12 ms is reached. The deference time remains at the upper limit of 12 ms until an access attempt is successful. The deference time is reinitialized after each successful access attempt.	Subclause 7.6.4
Response time	15.321c.5 The monitoring-system bandwidth shall be equal to or greater than the emission bandwidth of the intended transmission, and shall have a maximum reaction time less than $50 \times \sqrt{1.25/\text{emission bandwidth}}$, in MHz μ s for signals at the applicable threshold level, but shall not be required to be less than 50 μ s. If a signal is detected that is 6 dB or more above the threshold level, the maximum reaction time shall be $35 \times \sqrt{1.25/\text{emission bandwidth}}$, in MHz μ s, but shall not be required to be less than 35 μ s.	Subclause 7.6.3
Monitoring antenna	15.321c.6 The monitoring system shall use the same antenna used for transmission, or an antenna that yields equivalent reception at that location.	Clause 4
Monitoring threshold relaxation	15.321c.7 Devices that have a power output that is lower than the maximum permitted under the rules may increase their detection threshold by 1 dB for each 1 dB that the transmitter power is below the maximum permitted.	Clause 4
Adjacent channel emissions	15.321d Emissions shall be attenuated below a reference power of 112 mW as follows: 30 dB between the sub-band edges and 1.25 MHz above or below the sub-band; 50 dB between 1.25–2.5 MHz above or below the sub-band; and 60 dB at 2.5 MHz or greater above or below the sub-band. Compliance with the emissions limits is based on the use of measurement instrumentation that employs a peak detector function with an instrument RBW approximately equal to 1% of the emission bandwidth of the device under measurement.	Subclause 6.1.6
Carrier stability	15.321e	
Frequency stability	15.321e.1 The frequency stability of the carrier frequency of intentional radiators operating in this sub-band shall be ± 10 ppm over 10 ms or the interval between channel-access monitoring, whichever is shorter. The frequency stability shall be maintained over a temperature variation of -20 $^{\circ}$ C to $+50$ $^{\circ}$ C at normal supply voltage, and over a variation in the primary supply voltage of 85–115% of the rated supply voltage at a temperature of 20 $^{\circ}$ C.	Subclause 6.2.2
Frequency stability (with battery)	15.321e.2 For equipment that is capable of operating only from a battery, the frequency-stability tests shall be performed using a new battery without any further requirement to vary supply voltage.	Subclause 6.2.2
Maximum transmit period	15.321f An asynchronous transmission burst is a series of transmissions from one or more transmitters acting cooperatively. The transmission burst duration from one device or group of devices acting cooperatively shall be no greater than 10 ms. Any intraburst gap between cooperating devices shall not exceed 25 μ s.	Subclause 7.6.2

Annex B

(informative)

Notes on alternative monitoring procedure

As an alternate procedure, it would be possible to observe, in detail, the regions of the sub-band selected by the EUT and to observe that the EUT changes its operation to a clear region of the sub-band when interfering signals are introduced to its normal operating region. In some other cases, it may be easiest to constrain the device to operate in only a single channel through special operating controls (i.e., administrative commands to exclude operation on certain frequencies), in which case it would not be necessary to provide interference in regions other than the regions of the sub-band to be used during testing. Some devices may provide a test mode of operation in which they constrain their operation to selected operating regions of the sub-band. However, to be complete, these tests would need to be supplemented by an additional test to be sure the device deferred operation properly when the whole sub-band was occupied.

Annex C

(informative)

Power spectral density

C.1 Introduction

Limits on in-band and out-of-band power spectral density (PSD) are specified typically by regulatory agencies to control interference among different services and devices. The purpose of this annex is to explain the relationship between PSD and actual signal measurements (e.g., with a spectrum analyzer), and to show why accurate PSD measurements require the averaging of multiple individual measurements.

The instantaneous power-per-Hz, for an information-bearing signal, is inherently a random process with a mean equal to the actual PSD. The average power output from a narrowband (relative to the signal) measurement filter (e.g., a spectrum analyzer resolution filter) is the PSD at the filter center frequency multiplied by the filter noise bandwidth. The instantaneous filter output is a random process. As the bandwidth of the measurement filter becomes smaller compared to the signal bandwidth, the distribution of the filter output voltage approaches Gaussian; so the envelope distribution approaches Rayleigh and the envelope power distribution approaches exponential. Since a narrow-resolution bandwidth (relative to the signal bandwidth) is typically used to measure the power spectrum, the filter power output therefore can be approximated as an exponentially-distributed random variable with a mean equal to the PSD at the filter center frequency multiplied by the filter noise bandwidth. Therefore, because of the large variability in the filter output,⁴⁰ multiple samples shall be averaged to obtain an accurate measure of the PSD. While the use of a “peak hold” measurement on a spectrum analyzer provides a smooth trace, it can overstate the PSD by an error on the order of 10 dB.

C.2 Definition of power spectral density

The power spectrum or power spectral density (PSD) is the most meaningful measure of the “spectrum” of an information-modulated signal, which is inherently a random process. The PSD is the average power-per-unit bandwidth, as a function of frequency. PSD is defined mathematically, for a stationary random process, $x(t)$, as the Fourier transform of the autocorrelation function:

$$S_{xx}(f) = \int_{-\infty}^{\infty} R_{xx}(\tau) e^{-j2\pi f\tau} d\tau \text{ W/Hz} \quad (\text{C.1})$$

where the autocorrelation is:

$$R_{xx}(\tau) = E[\mathbf{x}(t)\mathbf{x}(t + \tau)] \quad (\text{C.2})$$

with $E[\cdot]$ denoting expectation (i.e., statistical average value). For an information-bearing signal consisting of a sequence of symbols with duration T_S , the autocorrelation will be non-zero only within a symbol or two of $\tau = 0$. That is, $R_{xx}(\tau) = 0$, $|\tau| > T_C$, where T_C depends on the baseband pulse-shaping, but typically will be on the order of a few symbol times.

C.3 Relationship between PSD and the Fourier transform of a signal

Assuming the expectation in Equation (C.2) is taken only over time intervals during which actual transmission is occurring, the PSD represents the *average* power-per-Hz, as a function of frequency, during transmission. This can be seen by considering the Fourier transform, observed at time t , of a transmission that starts at time 0:

⁴⁰This phenomenon is the reason that a single-sweep trace on a spectrum analyzer (with normal or sample detection) appears “rough.”

$$X(f, t) \equiv \int_0^t x(t) e^{-j2\pi f t} dt \quad (\text{C.3})$$

Clearly, $X(f, t)$ is a random function, since it is derived from the random signal, $x(t)$. The energy spectral density at time t is $|X(f, t)|^2$ J/Hz, and the instantaneous power-per-hertz is $d|X(f, t)|^2/dt$. The expected value of this is the actual power spectral density, as can be seen from

$$\left| X(f, t) \right|^2 = X(f, t) X^*(f, t) = \int_0^t dt_2 \int_0^t x(t_2) x(t_1) e^{-j2\pi f (t_1 - t_2)} dt_1 \quad (\text{C.4})$$

which has an expected value of:

$$E \left[\left| X(f, t) \right|^2 \right] = \int_0^t dt_2 \int_0^t R_{\mathbf{xx}}(t_1 - t_2) e^{-j2\pi f (t_1 - t_2)} dt_1 \quad (\text{C.5})$$

Substituting $\tau = t_1 - t_2$ and $\xi = t_1 + t_2$ (see Figure C.1), the area element in the new coordinate system is

$$dt d\mathbf{x} = \left| \begin{array}{cc} \frac{\partial t}{\partial t_1} & \frac{\partial t}{\partial t_2} \\ \frac{\partial \mathbf{x}}{\partial t_1} & \frac{\partial \mathbf{x}}{\partial t_2} \end{array} \right| dt_1 dt_2 = 2 dt_1 dt_2 \quad (\text{C.6})$$

and Equation (C.5) becomes:

$$E \left[\left| X(f, t) \right|^2 \right] = \frac{1}{2} \int_{-t}^t R_{\mathbf{xx}}(\tau) e^{-j2\pi f \tau} d\tau \int_{|\tau|}^t d\mathbf{x} = \int_{-t}^t R_{\mathbf{xx}}(\tau) e^{-j2\pi f \tau} (t - |\tau|) d\tau \quad (\text{C.7})$$

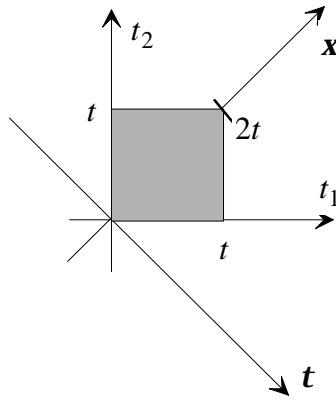

Figure C.1—Coordinate transformation of Equations (C.6) and (C.7)

Since $R_{\mathbf{xx}}(\tau) = 0$ for $\tau > T_C$,

$$E \left[\left| X(f, t) \right|^2 \right] = \int_{-T_C}^{T_C} R_{\mathbf{xx}}(\tau) e^{-j2\pi f \tau} (t - |\tau|) d\tau, \quad \text{for } t \geq T_C \quad (\text{C.8})$$

The instantaneous power-per-hertz is

$$f_x(f, t) \equiv \frac{d}{dt} |X(f, t)|^2 \text{ W/Hz} \quad (\text{C.9})$$

and its expected value, when the observation time exceeds T_C , is

$$E[f_x(f, t)] = \frac{d}{dt} E\left[|X(f, t)|^2\right] = \int_{-T_C}^{T_C} R_{\mathbf{xx}}(t) e^{-j2\pi ft} dt = S_{\mathbf{xx}}(f), \quad t \geq T_C \quad (\text{C.10})$$

Hence, the power-per-hertz, $\phi_x(f, t)$, is itself a random process, and its expected value is the PSD of the process $\mathbf{x}(t)$.

C.4 Spectrum analyzer resolution filter output

A spectrum analyzer effectively sweeps a narrowband resolution filter across the signal passband; and the filter output signal controls the instrument's display, which gives a representation of the signal spectral content. To specify appropriate measurement procedures for PSD, it is necessary to understand the relationship between the PSD and the output of the spectrum analyzer resolution filter.

Let $h(t)$ represent the impulse response of the resolution filter, and its Fourier transform, $H(f)$, the corresponding frequency-domain transfer function. It is assumed that the filter is causal [i.e., $h(t) = 0$ for $t < 0$] and that transmission begins at time 0. The filter output, $y(t)$, is then given by the convolution integral,

$$y(t) = \int_0^t x(\mathbf{t}) h(t - \mathbf{t}) d\mathbf{t} \quad (\text{C.11})$$

The filter has some time constant, t_h (i.e., $h(t) \approx 0$ for $t > t_h$), that varies inversely with its bandwidth. It is assumed here that the duration of the transmission is large compared to t_h , and that transient effects are ignored; in which case Equation (C.11) can be written as

$$\begin{aligned} y(t) &= \int_0^t x(\mathbf{t}) d\mathbf{t} \int_{-\infty}^{\infty} H(f) e^{j2\pi f(t-\mathbf{t})} df = \int_{-\infty}^{\infty} H(f) e^{j2\pi ft} df \int_0^t x(\mathbf{t}) e^{-j2\pi f\mathbf{t}} d\mathbf{t} \\ &= \int_{-\infty}^{\infty} H(f) X(f, t) e^{j2\pi ft} df \quad t \gg t_h \end{aligned} \quad (\text{C.12})$$

The power spectrum of $y(t)$ is related to that of $x(t)$ by

$$S_{yy}(f) = |H(f)|^2 S_{\mathbf{xx}}(f) \quad (\text{C.13})$$

and

$$E[y^2(t)] = \int_{-\infty}^{\infty} S_{yy}(f) df = \int_{-\infty}^{\infty} S_{\mathbf{xx}}(f) |H(f)|^2 df, \quad t \gg t_h \quad (\text{C.14})$$

If the filter has a nominal center frequency of f_0 and an effective noise bandwidth of B_N , defined as

$$B_N = \frac{\int_0^{\infty} |H(f)|^2 df}{|H(f_0)|^2} \quad (\text{C.15})$$

then, for $B_N \ll 1/T_s$, $S_{\mathbf{xx}}(f)$ is relatively constant over the filter passband, and

$$E[y^2(t)] \cong 2B_N |H(f_0)|^2 S_{xx}(f_0) \quad (\text{C.16})$$

Generally, the spectrum analyzer display is normalized so that, in effect, $|H(f_0)| = 1$. The factor of 2 in Equation (C.16) accounts for the fact that all frequency functions, including the PSD, $S_{xx}(f)$, are assumed to be two-sided for mathematical symmetry.

C.5 Statistical properties of the resolution filter output

The output of the resolution filter is a random process, since the input is a random process. It has been shown that the average (expected) value of the filter power output is proportional to the filter bandwidth and the PSD of the signal being measured. What remains is to characterize the statistical properties of the filter output.

In general, the resolution filter output, as a time function, is given by

$$y(t) = x(t) * h(t) = \int_{-\infty}^{\infty} x(\mathbf{t}) h(t - \mathbf{t}) d\mathbf{t} \quad (\text{C.17})$$

where

* denotes convolution.

Equivalently, in the frequency domain,

$$Y(f) = H(f) X(f) \quad (\text{C.18})$$

An important class of signals is that for which a single carrier of frequency f_c is amplitude-modulated and/or phase-modulated, which in general can be represented by

$$x(t) = r(t) \cos[2\pi f_c t + \mathbf{q}(t)] = \text{Re}\{v(t) e^{j2\pi f_c t}\} \quad (\text{C.19})$$

where

$$v(t) = r(t) e^{j\theta(t)},$$

$\text{Re}\{\cdot\}$ denotes the real part of the argument.

In the frequency domain,

$$X(f) = \frac{1}{2} V(f - f_c) + \frac{1}{2} V^*(-f - f_c) \quad (\text{C.20})$$

The process, $x(t)$, is assumed to be bandpass (i.e., $1/T_s \ll f_c$). Note that $v(t)$, sometimes called the “complex envelope” of $x(t)$, is actually a low-pass version of $x(t)$. The filter output, $y(t)$, can be expressed in a similar form:

$$y(t) = \text{Re}\{w(t) e^{j2\pi f_0 t}\} \quad (\text{C.21})$$

$$Y(f) = \frac{1}{2} W(f - f_0) + \frac{1}{2} W^*(-f - f_0) \quad (\text{C.22})$$

It is assumed in Equation (C.21) and (C.22) that the nominal filter center frequency is f_0 , and the filter is narrowband compared to $x(t)$.

The (bandpass) filter response may also be expressed in terms of an equivalent lowpass response, $H_{lp}(f)$:⁴¹

$$H(f) = H_{lp}(f - f_0) + H_{lp}^*(-f - f_0) \quad (C.23)$$

Since $x(t)$, $h(t)$, and $y(t)$ are real, their transforms are conjugate-symmetric [e.g., $X(f) = X^*(-f)$]. Therefore, it is possible to analyze the filter output based on positive frequencies only, and Equations (C.18) and (C.20) through (C.23) give:

$$W(f - f_0) = V(f - f_c)H_{lp}(f - f_0) \quad (C.24)$$

Letting $\Delta_f = f_c - f_0$,

$$W(f) = V(f - \Delta_f)H_{lp}(f) \quad (C.25)$$

and

$$w(t) = h_{lp}(t) * [v(t)e^{j2\pi\Delta_f t}] = \int_{-\infty}^{\infty} h_{lp}(t - \tau)v(\tau)e^{j2\pi\Delta_f \tau} d\tau \quad (C.26)$$

or, letting $V_{\Delta}(f) \equiv V(f - \Delta_f)$, so that $v_{\Delta}(t) = v(t)e^{j2\pi\Delta_f t} = r(t)e^{j[\theta(t) + 2\pi\Delta_f t]}$, gives:

$$w(t) = \int_{-\infty}^{\infty} h_{lp}(t - \tau)v_{\Delta}(\tau) d\tau \quad (C.27)$$

Figure C.2 gives an illustrative example of the relationships among the various frequency-domain functions.

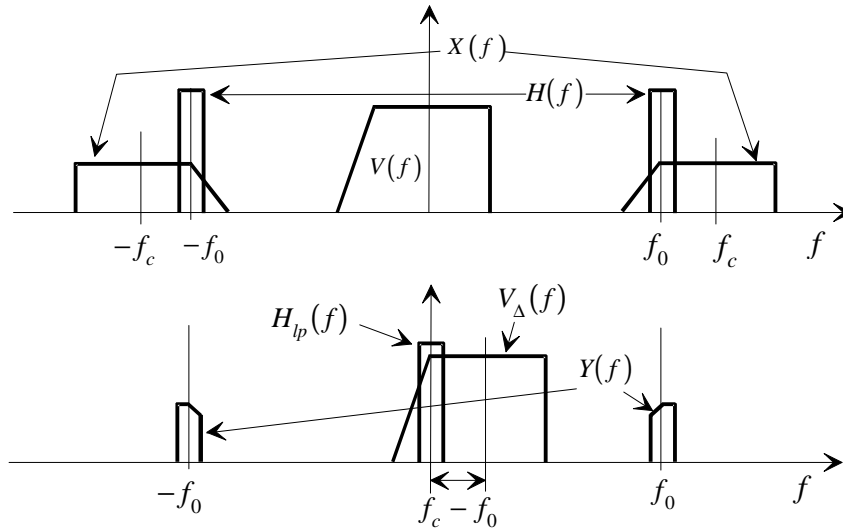

Figure C.2—Example signal spectra and filter characteristic

In general, both $h_{lp}(t)$ and $v_{\Delta}(t)$ are complex and can be expressed in terms of real time functions as

⁴¹The “center frequency” can be selected arbitrarily within limits, but typically would be the geometric center of the one-sided frequency response characteristic.

$$h_p(t) = p(t) + jq(t) \quad (\text{C.28})$$

$$v_\Delta(t) = a(t) + jb(t) \quad (\text{C.29})$$

where

$p(t)$, $q(t)$, $a(t)$, and $b(t)$ are real.

It is well known (and can be easily shown) that if and only if the process, $v_\Delta(t)$, is wide-sense stationary, then $R_{aa}(\tau) = R_{bb}(\tau)$ and $R_{ab}(\tau) = -R_{ba}(\tau)$.⁴² Since (by definition) $R_{ba}(\tau) = R_{ab}(-\tau)$, it follows that $R_{ab}(\tau) = -R_{ab}(-\tau)$; i.e., $R_{ab}(\tau)$ is odd. Therefore, $R_{ab}(0) = 0$; i.e., $a(t)$ and $b(t)$ are uncorrelated, although $a(t)$ and $b(t + \tau)$ may be correlated.

The equivalent lowpass filter output can be written in terms of real and imaginary components as

$$w(t) = c(t) + jd(t) \quad (\text{C.30})$$

where, from Equation (C.28),

$$c(t) = a(t)*p(t) - b(t)*q(t) \quad (\text{C.31})$$

$$d(t) = b(t)*p(t) + a(t)*q(t) \quad (\text{C.32})$$

It can be shown explicitly (see the note at the end of this annex) that $R_{cc}(\tau) = R_{dd}(\tau)$, $R_{cc}(\tau) = R_{cc}(-\tau)$, and $R_{dc}(\tau) = -R_{cd}(\tau)$. Hence, $R_{cd}(0) = 0$; i.e., $c(t)$ and $d(t)$ are uncorrelated [it also follows that $w(t)$ is wide-sense stationary, as would be expected].

It also can be shown that when the input of a lowpass filter is a stationary random signal, samples of which are independent if they are more than α seconds apart (as is the case here, with $\alpha = T_C$), then, as the filter bandwidth becomes small relative to the bandwidth of the input signal, the distribution of the filter output approaches Gaussian.⁴³

Conceptually, the reason for the approach to a Gaussian distribution is that the filter is effectively an integrator, and its integration time is inversely proportional to its bandwidth. Therefore, as the filter integration time becomes large compared to the correlation time, T_C , of the input process, the filter output is the sum of many independent integrated time segments of the input process. The Central Limit Theorem suggests that the sum tends toward a Gaussian distribution.

Therefore, the convolution terms, $a(t)*p(t)$, etc., in Equations (C.31) and (C.32) tend toward Gaussian as the resolution filter bandwidth, B_N , becomes small relative to $1/T_s$ (which is proportional to the signal bandwidth). Consequently, $c(t)$ and $d(t)$ are random variables that approach Gaussian for $B_N \ll 1/T_s$. Since $c(t)$ and $d(t)$ are uncorrelated, they are also independent if they are Gaussian. It is well known that the signal envelope, which is the quadrature sum of independent Gaussian terms, is Rayleigh-distributed, and that the square of the envelope (representing envelope power) is exponentially-distributed.⁴⁴ The envelope of $y(t)$ therefore approaches a Rayleigh distribution, and the envelope power approaches an exponential distribution. Defining the envelope power as the average power over an RF cycle as

⁴²See Papoulis, A., *Probability, Random Variables, and Stochastic Processes, 3rd Edition*, New York, NY: McGraw-Hill, 1991, Section 11-3.

⁴³See Papoulis, A., "Narrow-Band Systems and Gaussianity," *IEEE Transactions on Information Theory*, vol. IT-18, no. 1, pp. 20-27, Jan. 1972.

⁴⁴See, e.g., Papoulis, 1991, p. 146.

$$P_y(t) = \frac{|w(t)|^2}{2} \tag{C.33}$$

it is clear from Equation (C.16) that $P_y(t)$ can be expressed as

$$P_y(t) = 2\mathbf{y}(t)B_N \left| H(f_0) \right|^2 S_{xx}(f_0) \tag{C.34}$$

where

$\mathbf{y}(t)$ is an exponentially-distributed random process with a mean value of 1.

The probability density function (pdf) of $\mathbf{y}(t)$ is

$$f_y(x) = e^{-x}, \quad x \geq 0 \tag{C.35}$$

Figure C.3 shows the exponential distribution, $F_y(x) = \Pr\{\mathbf{y} < x\} = 1 - e^{-x}$, with $\bar{\mathbf{y}} = 1$.

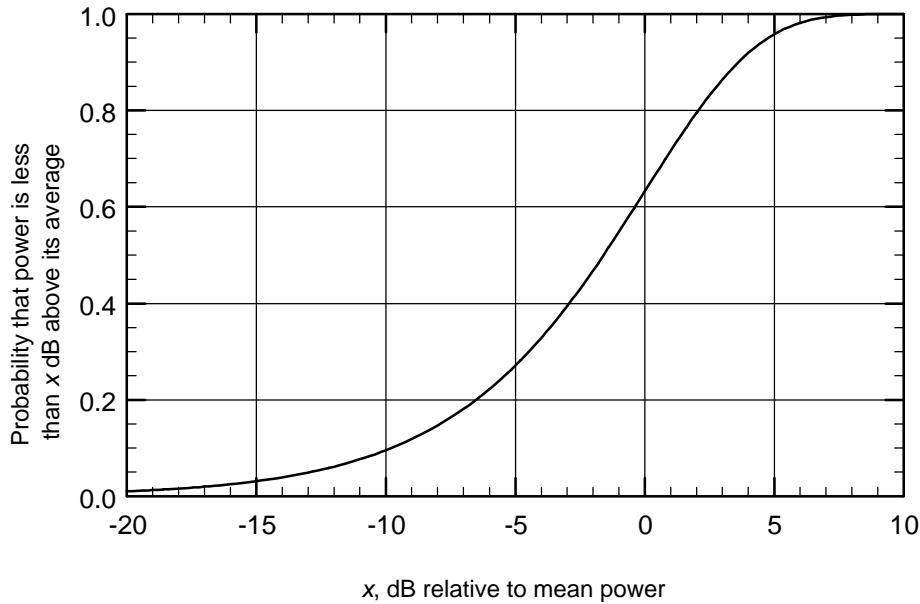

Figure C.3—The exponential distribution

If the maximum of many samples of the filter power output is used to estimate the PSD (e.g., using a spectrum analyzer’s “peak hold” function), the error will be on the order of 8–10 dB, depending on how close the filter output power distribution is to exponential, and also depending on the sweep time.

However, if the filter output power is averaged over a time interval that is large compared to the inverse of the filter bandwidth, a good estimate of the actual PSD can be obtained. The averaging shall be done on linear power samples, rather than on dB samples. For an exponential random variable, the dB error that will result from averaging dB samples can be computed by finding the average of $u = 10 \log v$:

$$E[u] = \int_0^{\infty} 10 \log v \cdot e^{-v} dv = \frac{10}{\ln 10} \int_0^{\infty} \ln v \cdot e^{-v} dv = -2.51 \text{ dB} \tag{C.36}$$

Thus, the dB average will be 2.51 dB less than the dB value of the linear average.

C.6 Conclusion

It has been shown that the instantaneous power-per-Hz of a random (i.e., information-modulated) waveform is itself a random process with a mean equal to the actual power spectral density (power spectrum) of the signal. When measuring the PSD, the bandwidth of the measurement instrument is typically narrow relative to the signal bandwidth, to provide the necessary spectral resolution. When that is the case, the filter output envelope power is random, with a distribution that approaches exponential and a mean that equals the PSD of the input signal at the filter center frequency, multiplied by the filter noise bandwidth. Because of the variability of the filter output, an accurate measure of the input signal PSD can be obtained only by averaging the output of the measurement filter in some manner. Otherwise, the measurement can overstate the PSD by an error on the order of 10 dB. Therefore, the use of a spectrum analyzer's peak hold or max hold function will not give an accurate PSD measurement, even though it provides a smooth visual trace.

NOTE—Auto-correlation and cross-correlation of the filter output in-phase and quadrature terms:

Assume that the jointly wide-sense stationary processes $\alpha(t)$ and $\beta(t)$ have a cross-correlation, $R_{\alpha\beta}(\tau)$, and a cross power spectrum, $S_{\alpha\beta}(f) = \int_{-\infty}^{\infty} R_{\alpha\beta}(\tau) e^{-j2\pi f\tau} d\tau$. If $\alpha(t)$ and $\beta(t)$ are applied to separate filters with respective impulse responses, $p(t)$ and $q(t)$, and the respective outputs are $y(t)$ and $\xi(t)$, then:

$$\gamma(t) = \alpha(t) * p(t)$$

$$\xi(t) = \beta(t) * q(t)$$

The cross-correlation of the outputs is

$$R_{\gamma\xi}(t) = E[\gamma^*(t)\xi(t+t)] = E\left[\int_{-\infty}^{\infty} \int_{-\infty}^{\infty} \mathbf{a}^*(t-v)\mathbf{b}(t+t-u)p^*(v)q(u)dvdu\right]$$

Since $E[\mathbf{a}^*(t-v)\mathbf{b}(t+t-u)] = R_{ab}(t+v-u)$, this becomes:

$$R_{\gamma\xi}(t) = \int_{-\infty}^{\infty} \int_{-\infty}^{\infty} R_{ab}(t+v-u)p^*(v)q(u)dvdu$$

Since $\int_{-\infty}^{\infty} R_{ab}(t+v-u)q(u)du = R_{ab}(t+v)*q(t+v) = \int_{-\infty}^{\infty} S_{ab}(f)Q(f)e^{j2\pi f(t+v)}df$ (where the first equality follows from the definition of convolution and the second from the convolution theorem), then

$$R_{\gamma\xi}(t) = \int_{-\infty}^{\infty} S_{ab}(f)Q(f)e^{j2\pi ft}df \int_{-\infty}^{\infty} p^*(v)e^{j2\pi fv}dv = \int_{-\infty}^{\infty} S_{ab}(f)Q(f)P^*(f)e^{j2\pi ft}df$$

This is in the form of an inverse Fourier transform, and it is evident that the cross-power spectrum is

$$S_{\gamma\xi}(f) = S_{ab}(f)Q(f)P^*(f)$$

Applying this result to $c(t)$ and $d(t)$, as defined in Equations (C.31) and (C.32), gives:

$$S_{cd}(f) = S_{ab}(f)|P(f)|^2 - S_{ba}(f)|Q(f)|^2 + S_{aa}(f)P^*(f)Q(f) - S_{bb}(f)Q^*(f)P(f)$$

With $S_{ab}(f) = -S_{ba}(f)$ and $S_{aa}(f) = S_{bb}(f)$,

$$S_{cd}(f) = S_{aa}(f)[P^*(f)Q(f) - Q^*(f)P(f)] + S_{ab}(f)[|P(f)|^2 + |Q(f)|^2]$$

$S_{aa}(f)$, $|P(f)|^2$, and $|Q(f)|^2$ are real, even functions of frequency. $S_{ab}(f)$ and $P^*(f)Q(f) - Q^*(f)P(f)$ are imaginary and odd. Hence, $S_{cd}(f)$ is imaginary and odd. Moreover, $S_{dc}(f) = -S_{cd}(f)$, so $R_{dc}(\tau) = -R_{cd}(\tau)$, $R_{cd}(\tau) = -R_{cd}(-\tau)$, and $R_{cd}(0) = 0$. Therefore, $c(t)$ and $d(t)$ are uncorrelated, although $c(t)$ and $d(t+\tau)$ may be correlated.

Also,

$$S_{cc}(f) = S_{dd}(f) = S_{aa}(f)[|P(f)|^2 + |Q(f)|^2] + S_{ab}(f)[P(f)Q^*(f) - P^*(f)Q(f)]$$

which is real and even. Hence, $R_{cc}(\tau) = R_{dd}(\tau)$ and $R_{cc}(\tau) = R_{cc}(-\tau)$. Therefore, the process, $w(t) = c(t) + jd(t)$, is wide-sense stationary.

Annex D

(informative)

Radiated and conducted measurement of power output and monitoring thresholds

This annex contains derivations and rationale to support the procedures of Clause 4.

D.1 General

To measure relative values of the EMC (electromagnetic compatibility) and OC (operational compatibility) test signals, or to sample the signal for further relative analysis, measurements can be performed at noncalibrated test facilities.

D.1.1 Detachable antennas

If the EUT has a detachable antenna(s), conducted measurements are preferred. Conducted measurements do not require a facility that complies with the requirements of ANSI C63.4-1992. In addition to the conducted measurements of emissions power and monitoring threshold, radiated tests of the EUT transmit antenna gain and the EUT transmit and monitoring system coverage equivalency may be necessary. If so, the EUT antenna-related parameters should be tested as recommended by the IEEE Std 149-1979 or equivalent documents. As a rule, the radiated measurements shall be performed at a test facility that meets the free-space requirements as set forth in Clause 6. To measure absolute values of conducted test signals, noncalibrated signals can be used. To measure absolute values of radiated signals, calibrated test facilities shall be used.

D.1.2 Nondetachable antennas

Radiated measurements of the EMC and OC characteristics shall be performed on equipment with nondetachable antennas, even when the EMC and OC performance limits are specified in terms of conducted units. In this case, the radiated test results obtained shall be correlated with specified conducted limits. When necessary, the EUT antenna-related parameters should be tested as recommended by IEEE Std 149-1979 or equivalent documents. As a rule, the radiated measurements shall be performed at a test facility that meets the free-space requirements as set forth in Clause 4.

D.1.3 Alternative test facilities, measurement techniques, and test-site validation

The preferred radiated test environment is free space. In a simulated free-space environment there are no requirements for the ground plane of the facility. Alternative test environments and techniques are also permitted, provided that their correlation with the preferred methods can be demonstrated. If the test methods are not given in the present standard, the procedures recommended by ANSI C63.4-1992 and other applicable standards shall be used. When TEM cell-based test facilities are used (e.g., a WB-TEM cell), the measured quantity is not field strength but rather radiated power. In this case, the computation of radiated parameters shall be performed according to the facility manufacturer's instructions, and correlated with free-space measurements. Test-site validation documentation shall be provided in the test report that demonstrates either the required ratio of direct and reflected signal components for approximating the free-space environment or correlation with recommended methods for alternative techniques (e.g., a WB-TEM cell).

D.2 Power limits

D.2.1 Transmit power limits

The maximum EUT transmit power, in W, at the transmit antenna terminals is $P_{\max} = 10^{-4} \sqrt{B}$, where B is the EUT emission bandwidth, in Hz. In dBm, $P_{\max} = 5 \log B - 10$. The actual EUT transmit power, P_{EUT} , shall be reduced below this limit by the amount that the directive gain of the EUT transmit antenna (relative to an isotropic antenna) exceeds a certain value, g , which is specified in the applicable regulations.⁴⁵ Therefore,

$$P_{EUT} \leq \begin{cases} P_{\max} - (G_A - g), & \text{when } G_A > g \\ P_{\max}, & \text{when } G_A \leq g \end{cases} \quad (\text{D.1})$$

where

G_A is the maximum directional gain of the EUT transmit antenna.

D.2.2 Monitoring threshold limits

The maximum monitoring threshold, T_{Mi} , at the terminals of an isotropic monitoring antenna, for a device transmitting the maximum allowed power, is M dB above kT_0B , where Boltzmann's constant $k = 1.38 \times 10^{-23} \text{W/}^\circ\text{K} \cdot \text{Hz}$, $T_0 = 290$ °K, and M takes on a value of 30 dB, 32 dB, or 50 dB, according to the device type. That is,

$$T_{Mi} = -174 + 10 \log B + M, \text{ dBm} \quad (\text{D.2})$$

The actual monitoring threshold limit, T_M , increases above by the difference between P_{\max} and P_{EUT} . Therefore, the actual monitoring threshold limit is

$$T_M = T_{Mi} + P_{\max} - P_{EUT}, \text{ dBm} \quad (\text{D.3})$$

The monitoring threshold limit and the transmit power, therefore, are related by

$$T_M + P_{EUT} = T_{Mi} + P_{\max} = 15 \log B + M - 184, \text{ dBm} \quad (\text{D.4})$$

The effect of the rules, therefore, is to place an upper bound on the sum of the EUT transmit power and monitoring threshold (in dBm).

D.2.3 EIRP and electric field (E-field) threshold limits for radiated tests

For a device with a nondetachable antenna, the power shall be measured in terms of EIRP. Measurement of the monitoring thresholds shall be based on an equivalent E-field incident on the monitoring antenna. The required field strength can be calculated using

$$E_M = T_M + 20 \log f - 42.8 - G_A \quad (\text{D.5})$$

where

E_M is the received field strength, in $\text{dB}\mu\text{V/m}$ (aligned with the polarization of the monitoring antenna), required to produce a received power level of T_M , in dBm, at the terminals of the idealized lossless monitoring antenna with maximum directive gain, G_A .

⁴⁵47 CFR 15, Subpart D, 15.319(e), specifies that $g = 3$ dBi.

For the same antenna, the EIRP and the transmit power at the antenna terminals are related by

$$EIRP_{EUT} = P_{EUT} + G_A \quad (D.6)$$

Combining Equations (D.4), (D.5), and (D.6) gives

$$E_M + EIRP_{EUT} = T_{Mi} + P_{\max} + 20 \log f - 42.8 \quad (D.7)$$

which is equivalent to Equation (D.4), but for radiated measurements. Combining (D.1) and (D.6) gives the applicable EIRP limits as

$$EIRP_{EUT} \leq \begin{cases} P_{\max} + g, & \text{when } G_A > g \\ P_{\max} + G_A, & \text{when } G_A \leq g \end{cases} \quad (D.8)$$

D.2.4 Separate transmit and monitoring antennas

The EUT monitoring antenna shall provide coverage, equivalent to the EUT transmit antenna, that may result in further correction to the monitoring threshold. The following definition of equivalent coverage is adopted:

The monitoring system shall cause deference to any transmission of sufficient strength to induce a power level in the EUT transmit antenna that exceeds the maximum threshold allowed for the system under test, measured at the transmit antenna input.

In applying this principle to developing tests for equivalent coverage, the following assumptions are made:

- a) The distance between the transmit and monitoring antennas is not specified in the rules and therefore is determined by the system designer.
- b) There is no requirement that the gain and pattern characteristics of the transmit and monitoring antennas be identical.
- c) Reciprocity exists between transmit and receive gain and pattern characteristics of the transmit antenna, and the transmit antenna is essentially a lossless radiator.

To verify that the monitoring antenna has coverage equivalent to that of the transmitting antenna, it is necessary to demonstrate that the EUT defers if a received signal is sufficiently strong to generate a power level of T_M at the transmit antenna terminals.

D.3 Transmit power and monitoring threshold test method selection

Practical procedures to demonstrate compliance with the transmit power and monitoring threshold limits depend on the availability of the antenna terminals for measurements and the relationship between the transmit and monitoring antennas. This standard identifies six potential test configurations, which are given in the following table together with the associated subclause numbers.

Transmit/monitoring antenna comparison and placement	Standard subclause	
	Detachable antennas	Nondetachable antennas
Single, or identical collocated	4.4	4.7
Different collocated	4.5	4.8
Arbitrarily placed	4.6	4.9

D.3.1 Detachable transmit and monitoring antennas

If a single antenna performs both transmission and monitoring functions, or the transmit and monitoring antennas are separate but identical and collocated, the equivalent coverage requirements are always met, and Equation (D.4) fully determines the monitoring threshold. In this case, when the EUT antenna is detachable, testing to demonstrate compliance with the limits of Equations (D.1) and (D.4) requires determination of the antenna gain in the direction of maximum radiation, and conducted measurements of the EUT transmit power and monitoring threshold at the antenna terminals. The antenna gain in the direction of maximum radiation is determined from typical antenna measurements or the manufacturer's declaration. It may be possible to measure the EUT gain in facilities that measure radiated power, such as a WB-TEM cell. In this case, the correlation should be demonstrated with free-space antenna measurements. Detailed threshold measurements are described in Clause 7.

When the EUT transmit and monitoring antennas are detachable, but different and collocated, the limit of Equation (D.4) shall also account for the equivalent transmit/monitoring antenna coverage. The coverage measurements can be performed with a reference antenna that illuminates the EUT transmit and monitoring antennas, while maintaining a generated power level of T_M at the EUT transmit antenna terminals. The test is done with horizontally and vertically polarized reference antennas for a limited number of EUT orientations. Corresponding procedures can be devised when the tests are made at radiated-power measuring facilities (e.g., a WB-TEM cell).

If the transmit and monitoring antennas can be separated from each other by a maximum distance of s , it is suggested that the power, T_M , at the EUT transmit antenna terminals be established only for one point at a distance of r between the reference antenna and the EUT in the direction of EUT transmit antenna maximum radiation, by applying the corresponding power, P_{Tref} (see below), at the terminals of a reference antenna. Then, while the position of the reference antenna is not changed, the monitoring antenna is placed at a distance of $r + s$ from the reference antenna, and is positioned in multiple orientations. If the EUT fails to defer in any orientation, the reference antenna should be rotated 90° about the direction to the EUT. Only if the EUT again fails to defer should it be held noncompliant.

D.3.2 Nondetachable transmit and monitoring antennas

When access to the EUT antenna terminals is not available (i.e., antennas are nondetachable), only radiated measurements are possible, and tests for compliance with the rules shall be based on measurements of EIRP and the field-strength threshold limit, E_M . Procedures to determine the gain, G_A , of detachable antennas based on power comparison at the antenna terminals are not applicable. Several alternative test techniques are possible based on measurements of radiated field intensities and/or antenna-related parameters. The relationships given below allow the EIRP and the field strength threshold limit, E_M , to be determined in the free-space environment with a reference antenna, which is first used to measure the radiated field strength from the EUT, and is then used to generate a field incident at the EUT.

D.3.2.1 Relationships for radiated measurement of EIRP

In a free-space environment, the radiated-field intensity is related to the transmitted power at the antenna terminals by

$$E(\theta, \phi) = \frac{1}{r} \sqrt{30PG(\theta, \phi)} \text{ V/m} \quad (\text{D.9})$$

where

- P is the power (in W) applied to the EUT antenna terminals,
- r is the distance, in meters, from the antenna to the observation point,
- $G(\theta, \phi)$ is the directive gain of the transmit antenna in the (θ, ϕ) direction.

Converting to logarithmic units and considering the direction in which the EUT antenna gain achieves its maximum value, G_A , gives

$$E_{EUT\max} = P_{EUT} + G_A - 20\log_{10}r + 104.8 \text{ dB}\mu\text{V/m} \quad (\text{D.10})$$

where

G_A (dBi) is the maximum directive antenna gain of the EUT,
 P_{EUT} is in dBm.

From Equations (D.6) and (D.10), the EIRP is related to the measured field by

$$EIRP_{EUT} = E_{EUT\max} + 20\log_{10}r - 104.8 \quad (\text{D.11})$$

D.3.2.2 Relationships for radiated threshold measurements

The maximum monitoring threshold field strength limit, E_M , is related to the actual EIRP by Equation (D.7). The power, P_{Tref} , that shall be applied to a reference antenna to generate a field of strength E_M at the EUT transmit antenna (separated from the reference antenna by distance of r) can be found from equations describing the signal propagation at the test site. For example, the free-space relationship is

$$P_{Tref} = E_M + 20\log_{10}r - G_{REF} - 104.8 \quad (\text{D.12})$$

where

G_{REF} is the gain of the reference antenna in the direction of the EUT.

Since $T_M = P_{Tref} + 20\log(I/4\pi r) + G_A + G_{REF}$ (the Friis formula), P_{Tref} can be expressed in terms of EIRP using Equations (D.3) and (D.6) as

$$P_{Tref} = T_{Mi} + P_{\max} - EIRP_{EUT} - 20\log(I/4\pi r) - G_{REF} \quad (\text{D.13})$$

Equivalently, P_{Tref} can be expressed in terms of $E_{EUT\max}$ by substituting Equation (D.11) into (D.13), giving

$$P_{Tref} = T_{Mi} + P_{\max} - E_{EUT\max} + 20\log_{10}f - G_{REF} - 42.8 \quad (\text{D.14})$$

D.4 General guidelines on measurement conditions and procedures

D.4.1 Conducted measurements

When the transmit and monitoring system power can be measured at the EUT antenna terminals, these characteristics are tested with conducted measurements, and the procedures described in Clause 7 can be applied directly. Only the transmit antenna gain and the transmit and monitoring system equivalent reception tests shall be performed using radiated measurements.

The EUT transmit antenna gain is determined as recommended by IEEE Std 149-1979. For WB-TEMs, the test procedure is similar with that of the EUT being rotated within the cell. However, the measured quantity is not field strength but rather radiated power.

D.4.2 Radiated measurements

Since the measurement parameters and variables can be expressed in several different, albeit equivalent, ways, a number of test procedures can be used to evaluate the EUT with nondetachable antennas. As an example, some of those presented in the standard test procedures are based on free-space propagation (see Figure 2 and Subclause 4.6). Corresponding test procedures can be also based on facilities that measure radiated power (WB-TEM, etc.), where, instead of using the reference antenna, the necessary power levels are generated and/or measured by the test facility itself.

The preferred test environment for radiated measurements is “free space.” For purposes of the tests specified in this standard, the free-space environment can be realized in a WB-TEM or an anechoic chamber, or can be simulated at an OATS or semianechoic chamber by maintaining at least the 10 dB loss of the signal reflected from the ground plane to the line-of-sight signal. A simulated free-space environment can be achieved, for example, by lining the OATS or semianechoic chamber ground plane with RF absorber, by using the elevated test sites where both the EUT and the test antennas are placed at a sufficient distance (height) over the ground plane and other reflective objects, and by utilizing directive reference antennas, which reject the reflected wave to a sufficient degree.

In a simulated free-space environment, there are no specific requirements for the ground plane of the facility. The free-space and simulated free-space environment site validation documentation shall be provided, which demonstrates the required ratio of direct and reflected signal during the test.

To measure the EUT gain at facilities that make field-strength measurements, install the EUT at a nonconducting table or a turntable at the test site. Attach the EUT transmit antenna(s). Install a linearly polarized calibrated reference at a distance, $r_t > 2D^2/\lambda$, from the EUT, where D is the largest dimension of the EUT, and λ is the wavelength of the signal. Align the reference antenna for its major lobe facing the EUT. Configure the reference antenna as a receive antenna. Find the EUT direction of maximum radiation by measuring the EUT emissions at a sufficient number of equally spaced points on the surface of a sphere with a radius of r and the EUT transmit antenna at its center. This can be achieved, for example, by measuring the electric field intensity with horizontally and vertically polarized reference antenna, while moving the EUT within 0–360° azimuth and 0–180° elevation plane angle variations. After the direction of the EUT maximum radiation is found, the EUT gain, G_A , can be determined using standard procedures for antennas.

For facilities that measure radiated power, such as WB-TEMs, install the EUT in the center of the test volume using nonconductive material to position the unit. Find the EUT direction of maximum radiation by measuring the EUT emissions at a sufficient number of equally spaced points on the surface of a sphere surrounding the EUT. After the direction of the EUT maximum radiation is found, the EUT gain, G_A , can be determined using standard test procedures for antennas.

Annex E

(informative)

Monte Carlo routine for asynchronous back-off time distribution

```
/*=====
This is a Monte-Carlo routine to estimate the probability distribution
function of the interval between packets transmitted by a UPCS device
(below called the EUT) that is compliant with the asynchronous
rules under 47 CFR 15, Subpart D. The simulated experiment
is as follows.
```

The EUT transmits a packet. The end of the packet is observed by a test receiver (at time zero), and this event triggers transmission of a test signal above threshold, with uniform random duration of $0 \leq a \leq a_{max}$. During this test pulse, the EUT executes random backoff and observation according to the asynchronous access rules.

In the code below, the variable, *s*, represents the end of a 50 microsecond observation window -- the instant at which a hard decision shall be made to defer or to transmit.

Eventually, the EUT executes an observation window that falls after the end of the test pulse and, thus, the EUT transmits another packet. The intervals between the end of one EUT packet and the beginning of the next are recorded as a histogram while the interference pulse takes random durations. The histogram is normalized to (an estimate of) a probability density function, and this is integrated to a distribution function.

This computer-simulated (i.e., estimated) distribution function can be compared to one similarly acquired in an actual test of the candidate hardware. If the distribution measured with the actual EUT lies everywhere beneath the one calculated below, then the EUT's backoff algorithm is more polite than the one specified by FCC 47 CFR, Part 15, Subpart D, and the EUT passes this test.

Using an ancient version (2.0) of Quick C, the following command lines work.

```
\qc2\bin\qcl /Fpi /G2 /AC /F 4000 histo3.c <--(no coprocessor)
\qc2\bin\qcl /Fpi87 /G2 /AC /F 4000 histo3.c <--(coprocessor)
JWM, 13JUL95
=====*/
#include <stdio.h>
#include <math.h>
#include <stdlib.h>

main()
```

```

{
float a; /* test pulse length */
float amax; /* maximum test pulse length */
float D; /* backoff range */
float Dmin=750; /* minimum backoff range (microsec) */
float Dmax=12000; /* maximum backoff range (microsec) */
float s; /* time after end of last EUT transmission */
float N; /* trial counter */
float Ntrials; /* number of trials */
float sum=0; /* sum of histogram bins */
float histo[2400]; /* the histogram array */
long seed, i; /* not used */
FILE *fp_distro; /* output distribution */
FILE *fp_density; /* output density */

if((fp_distro=fopen("histo3.dis", "w"))==NULL)
{
printf("\nError opening distribution output file");
return;
}
if((fp_density=fopen("histo3.den", "w"))==NULL)
{
printf("\nError opening density output file");
return;
}
printf("\nEnter the number of trials to perform and the maximum\n");
printf("test pulse length in microseconds, e.g., 20000 12000\n");
scanf("%g %g", &Ntrials, &amax);

for(i=0; i<2400; i++) histo[i] = 0.; /* initialize the histogram */

for(N=1; N<=Ntrials; N++)
{
s = 0; /* clock starts at end of previous EUT transmission */
D = Dmin; /* reinit the backoff range */
a = (amax/32767.)*rand(); /* pick a test pulse length */
s = (D/32767.)*rand() + 50.; /* mandatory backoff and monitoring */
while(s<(a+50)) /* need whole window clear to escape loop */
{
if(D<Dmax) D = 2. * D; /* double range of uniform backoff */
s = s + (D/32767.)*rand() + 50.;
}
histo[(long)min(s/10., 2400.)]++;
}
for(i=0; i<2400; i++) histo[i] = histo[i]/Ntrials; /* normalize */
for(i=0; i<2400; i++) fprintf(fp_density, "%g\n", histo[i]);
for(i=1; i<2400; i++) histo[i] = histo[i-1] + histo[i]; /*integrate*/
for(i=0; i<2400; i++) fprintf(fp_distro, "%g\n",histo[i]) ;
printf("\nASCII output files histo3.dis and histo3.den are ready.\n");
}

```

Table F.1—Parameters and notation

Generator noise floor	kTn_G mW/Hz; $N_G = 10\log n_G$
Receiver noise floor	kTf mW/Hz; $F = 10\log f$ (noise figure)
Notch bandwidth	W_N Hz
Generator power spectral density	kTs_G mW/Hz; $S_G = 10\log s_G$
Generator dynamic range	$\delta_G = s_G/n_G$; $\Delta_G = S_G - N_G$ (dB)
Receiver noise bandwidth	B Hz
Receiver offset from nominal center frequency	δ_f Hz
Center frequency separation	f_Δ Hz

The equivalent noise bandwidth for $H(f)$ is defined as:

$$B = \frac{\int_{-\infty}^{\infty} |H(f)|^2 df}{|H(0)|^2}$$

S_G and N_G can be set to any desired level with an attenuator between the generator and the EUT, subject to the constraint, $S_G - N_G \leq \Delta_{Gmax}$, where Δ_{Gmax} is the maximum dynamic range of the generator. It will be assumed here that Δ_{Gmax} is on the order of 50 dB.

Using baseband equivalent frequency functions, the total “noise” power into the EUT is

$$P = |H(0)|^2 kTB(f + n_G) + kTs_G \left[\int_{-\infty}^{-d_f - W_N/2} |H(f)|^2 df + \int_{-d_f + W_N/2}^{\infty} |H(f)|^2 df \right] \quad (F.1)$$

For convenience, it has been assumed that $\delta_{Gmax} \gg 1$.

The first term represents the noise floor and the second term represents the generator signal power that gets through the receiver IF due to the imperfect selectivity. This second term determines the value of W_N required to maintain the noise power on the “targeted” channel at a level that will not interfere with the test being conducted.

F.2 Butterworth $H(f)$ example

To illustrate, assume that $H(f)$ has an n th order Butterworth characteristic. If B_C is the 3 dB bandwidth of the filter, the attenuation provided by the filter for a bandwidth, W (the separation between the two frequencies for which the attenuation the same), is

$$A(W) = 1 + \left(\frac{W}{B_C} \right)^{2n} \quad (F.2)$$

The filter center frequency is the geometric mean of the upper and lower 3 dB frequencies (or of any two frequencies with the same attenuation):

$$f_0 = \sqrt{f_U f_L} \quad (\text{F.3})$$

where

$$B_C = f_U - f_L.$$

Therefore,

$$A(f) = 1 + \left(\frac{f - f_0^2/f}{B_C} \right)^{2n} \quad (\text{F.4})$$

Normalizing with $x \triangleq \frac{f - f_0}{B_C}$, we have

$$A(x) = 1 + \left[x + \frac{f_0}{B_C} - \frac{1}{x(B_C/f_0)^2 + B_C/f_0} \right]^{2n} \quad (\text{F.5})$$

For $B_C/f_0 \ll 1$ (normally the case) and $|x| \ll f_0/B_C$ (the region of interest), the last term can be approximated as

$$\frac{1}{x(B_C/f_0)^2 + B_C/f_0} \cong \frac{f_0}{B_C} - x \quad (\text{F.6})$$

and Equation (F.5) becomes:

$$A(x) \cong 1 + (2x)^{2n} \quad (\text{F.7})$$

and

$$|H(f)|^2 \cong \frac{1}{1 + \left(2 \frac{f - f_0}{B_C} \right)^{2n}} \quad (\text{F.8})$$

For and $|x| \geq 1$ and $n \geq 2$,

$$|H(f)|^2 \approx \frac{1}{[2(f - f_0)/B_C]^{2n}} \quad (\text{F.9})$$

Figure F.2 shows the exact expression for $|H(f)|^2$ per Equation (F.5) and the approximations per Equations (F.8) and (F.9) for $B_C/f_0 = 0.05$.

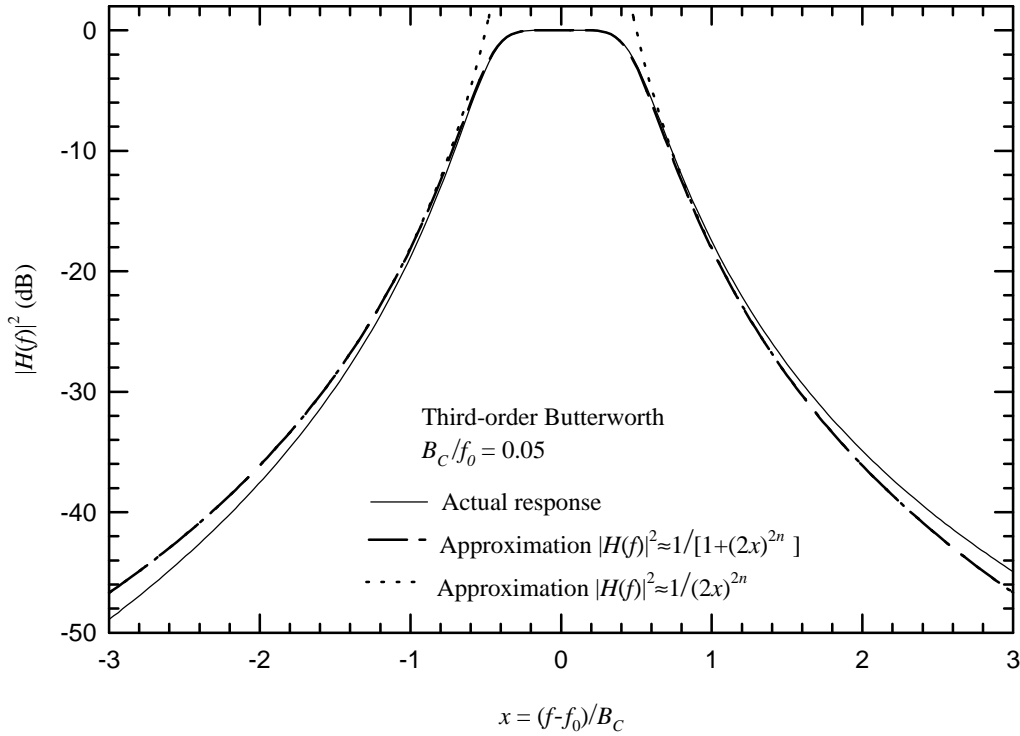

Figure F.2—Third-order Butterworth filter response and approximations

Note that since $\int_0^\infty \frac{1}{1+(W/B_C)^{2n}} dW = B_C \int_0^\infty \frac{1}{1+x^{2n}} dx = B_C \frac{p}{2n \sin(p/2n)} \approx B_C$ for $n \geq 3$, the effective noise bandwidth, B , is essentially the 3 dB bandwidth, B_C , for $n \geq 3$.

Substituting Equation (F.9) with $f_0 = 0$ and $\delta_f = 0$ into Equation (F.1) gives

$$P \cong kTB \left[f + n_G + \int_{W_N/B_C}^\infty \frac{S_G}{x^{2n}} dx \right] = kTB \left[f + n_G + \frac{S_G}{2n-1} \left(\frac{B}{W_N} \right)^{2n-1} \right] \tag{F.10}$$

F.3 Considerations for test procedures

F.3.1 Generator interference in the target channel shall be well below the threshold

P shall be significantly below the threshold being tested. Otherwise, the test results will be inaccurate. If the wideband interference is applied and a spectrum window (i.e., a notch) is opened, and widened until the EUT transmits, then P will be slightly below the threshold. The introduction of a narrowband test signal in the center of the notch will not need to be at the threshold to cause the EUT to defer. For example, assume that P is 1 dB below the threshold. The addition of a signal 6.8 dB below the threshold will cause deference, resulting in a 6.8 dB error in the measured threshold level. Figure F.3 shows the threshold measurement error, in dB, vs. the dB difference between P and the threshold. It can be seen that for reasonable accuracy, P shall be on the order of 10–15 dB below the threshold being measured, or the test would indicate a threshold below the actual threshold of the EUT. This could allow a noncompliant EUT (with too high a threshold) to pass the test; but it also could cause a compliant isochronous LIC device to fail the test for the lower thresh-

old (the lower threshold would appear too low relative to the upper threshold). This highlights an inherent problem in measuring lower thresholds near the device noise floor.⁴⁶

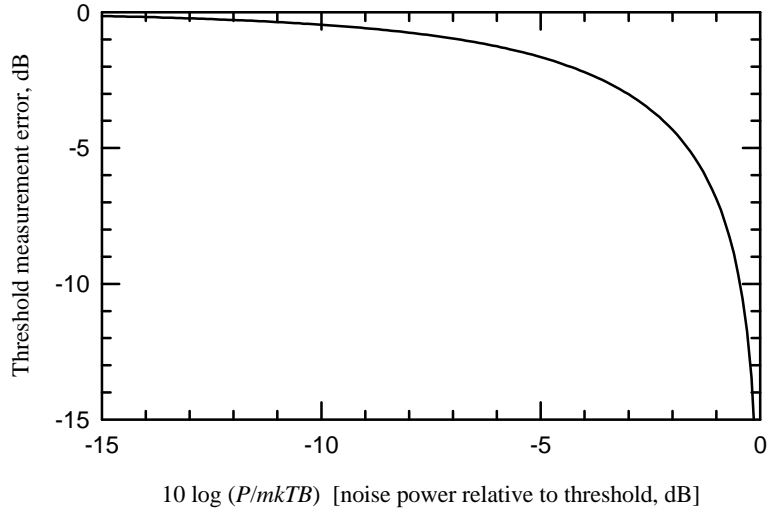

Figure F.3—Threshold measurement error (in dB) vs. the dB difference between P and the threshold

F.3.2 Interference shall be above threshold on nontargeted channels

It is necessary that S_G be X dB above the threshold, M (where M is in dB relative to kTB). Therefore, $s_G = xm$, where $x = 10^{X/10}$ and $m = 10^{M/10}$. Further, $s_G = \delta_G n_G$, reflecting the dynamic range limit of the generator. Finally, to avoid contaminating the test (as discussed above), P shall be Y dB below M . With $y = 10^{Y/10}$, we have, from Equation (F.10),

$$P = \frac{m}{y} kTB = kTB \left[f + \frac{xm}{d_G} + \frac{xm}{2n-1} \left(\frac{B}{W_N} \right)^{2n-1} \right] \quad (\text{F.11})$$

Therefore,

$$\frac{1}{xy} = \frac{f}{xm} + \frac{1}{d_G} + \frac{1}{2n-1} \left(\frac{B}{W_N} \right)^{2n-1} \quad (\text{F.12})$$

Note that $1/xy = P/kTBs_G$, the ratio of the residual interference plus noise power in the target channel to the out-of-operating-region interference.

Rearranging Equation (F.12) gives a form that is useful for exploring the limitations of using out-of-operating-region interference:

$$\frac{1}{x} \left(\frac{1}{y} - \frac{f}{m} \right) = \frac{1}{2n-1} \left(\frac{B}{W_N} \right)^{2n-1} + \frac{1}{d_G} \quad (\text{F.13})$$

The maximum value of x can be expressed as a function of W_N/B , given the other parameters, providing $1/y > f/m$ (i.e., the required “headroom” does not exceed the dB difference between the threshold and the device noise floor). For purposes of developing testing guidelines, the EUT device noise can be ignored,⁴⁷ and Y can be interpreted as the difference between the threshold and the residual power from the generator. In that case, assuming $\delta_G \gg xy$, Equation (F.13) gives

⁴⁶It also raises an interesting interpretation question regarding whether or not the monitored power level that is subject to the threshold requirements includes self-generated receiver device noise.

$$xy \approx (2n - 1) \left(\frac{W_N}{B_C} \right)^{2n-1} \tag{F.14}$$

F.3.3 Notches reduce interference power in the adjacent channel

If the EUT selectivity is poor, a relatively wide notch may be necessary to allow the out-of-operating-region interference to be sufficiently above the threshold while maintaining the residual generator power in the target channel adequately below threshold. A wide notch could cause the interference in the adjacent channel to drop below the threshold. If the channel center frequencies are separated by f_Δ , then the interference power in the adjacent channel is

$$P_{ADJ} = \frac{1}{2} kT s_G \int_{\frac{W_N}{2} - f_\Delta}^{\infty} |H(f)|^2 df = \frac{kTB_C s_G}{2} \int_{\frac{W_N}{B_C} - 2\alpha_\Delta}^{\infty} \frac{1}{1 + x^{2n}} dx \tag{F.15}$$

where

$$\alpha_\Delta = f_\Delta / B.$$

Figure F.4 shows the nonadjacent and adjacent-channel interference power as a function of W_N/B for $n = 3$. It was assumed that $\alpha_\Delta = 2$. Figure F.5 shows the same curves, but for $n = 2$. The integrals were computed numerically using Equations (F.1), (F.8), and (F.15).

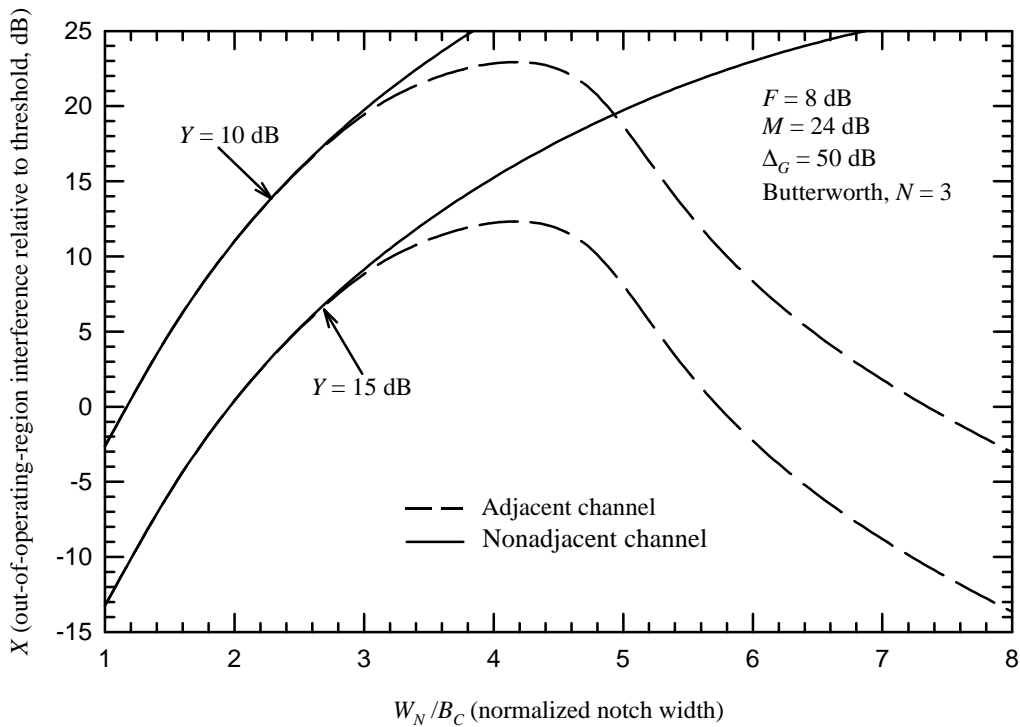

Figure F.4—Adjacent channel and nonadjacent channel interference power as a function of W_N/B_C for $N = 3$

⁴⁷This implies an assumption that the “threshold” is the amount of externally added power required to cause deference (i.e., it does not include receiver device noise). If this is not the case, the measurement error curve of Figure F.3 applies, except that the abscissa would be the ratio of receiver noise to the threshold. Therefore, a “double” correction would be necessary: one for the residual generator power, and the other for the receiver noise.

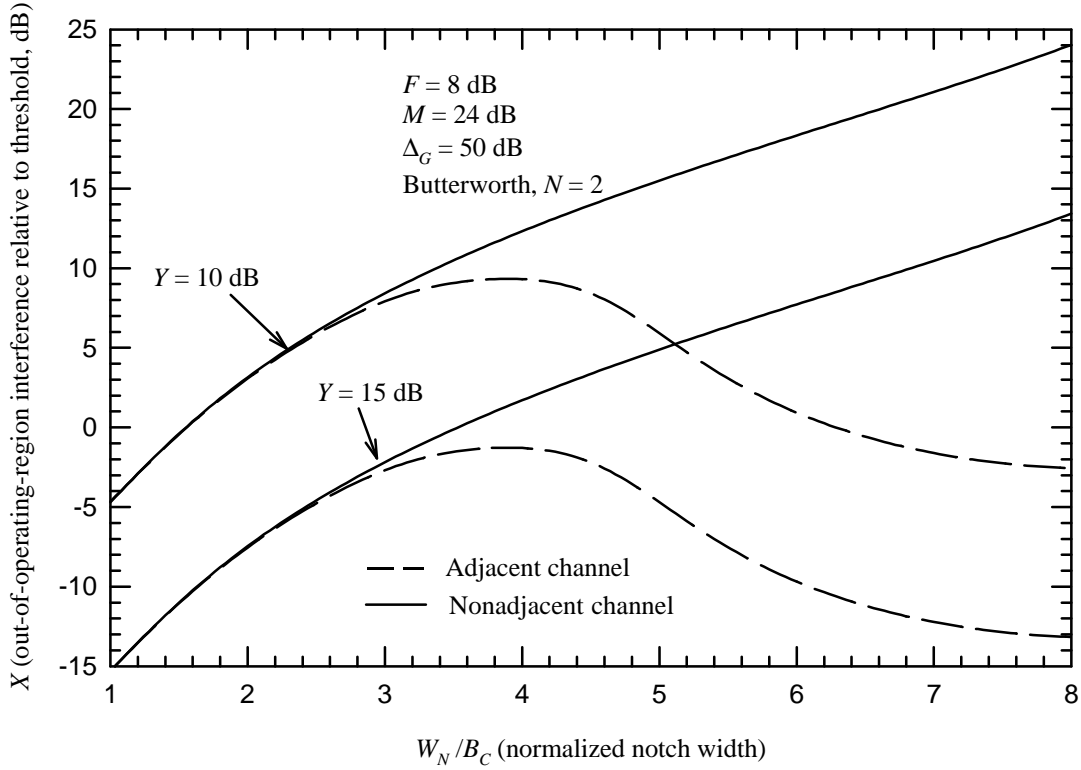

Figure F.5—Adjacent channel and nonadjacent channel interference power as a function of W_N/B_C for $N = 2$

Figure F.6 shows the same curves for $Y = 15$ dB, with EUT device noise ignored. In all cases (as would be expected), interference from the generator in the adjacent channel is down 3 dB from that in the nonadjacent channel, when the notch edge falls on the adjacent channel center frequency ($W_N = 2f_\Delta$). This is the point at which the interference from the generator is at a maximum in the adjacent channels, given the required value of Y (and the point at which $X + Y$ is maximized for the frequency adjacent to the target frequency).

If x_A is the ratio of the power in the adjacent channel to the threshold, then the maximum value of xy for the adjacent channel is

$$(x_A y)_{\max} = \frac{\int_{-\infty}^{\infty} |H(f)|^2}{|H(0)|^2 \left(\int_{-\infty}^{-f_\Delta} |H(f)|^2 df + \int_{f_\Delta}^{\infty} |H(f)|^2 df \right)} \quad (\text{F.16})$$

For the Butterworth example given here, this becomes, using the approximation of Equation (F.9),

$$(x_A y)_{\max} \approx \frac{p(2n-1)}{4n \sin(p/2n)} \left(\frac{2f_\Delta}{B_C} \right)^{2n-1} \quad (\text{F.17})$$

This is an important quantity, because it is the upper limit of the difference (in dB) between the residual interference power in the target channel and the interference power blocking the adjacent channel.

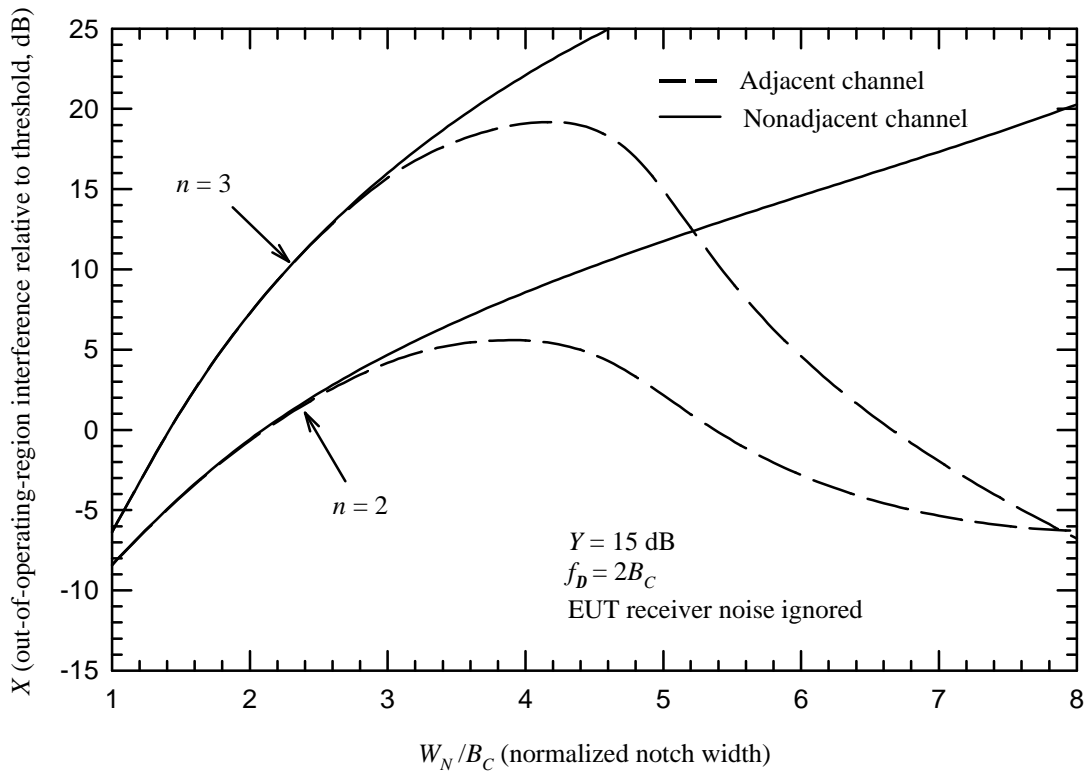

Figure F.6—Adjacent channel and nonadjacent channel interference power as a function of W_N/B_C for $Y = 15$ dB

F.4 Multicarrier interference generator

The EUT can be blocked from using selected frequencies by applying CW signals above threshold on those frequencies. For an EUT with a manageable number of frequencies, this suggests the possibility of an interference generator that consists simply of multiple oscillators tuned to the EUT center frequencies, each of which can be independently energized. The oscillator outputs would be combined (and amplified if necessary) to give a multicarrier RF output. The level of the output into the EUT could be controlled by a variable attenuator, as in the “square-notch” case. For an EUT with a large number of carrier frequencies, the actual combining of RF signals may be impractical, and digital synthesis or the square-notch approach could be used.

With the multicarrier (MC) approach, the analysis of the residual power in the target (nonblocked) frequency channel becomes simpler. The ratio of the residual power in the target channel to the power in the blocked channel is $|H(f_\Delta)|^2 + |H(-f_\Delta)|^2$, assuming that the upper and lower adjacent channels are blocked. It is also assumed that the residual power in the target channel from the carriers on nonadjacent channels is negligible. Thus, with the MC approach, Equation (F.14) becomes

$$xy = \frac{1}{|H(f_\Delta)|^2 + |H(-f_\Delta)|^2} \quad (\text{F.18})$$

For the Butterworth characteristic, using the approximation of (F.9), this becomes

$$xy \approx \frac{(2f_{\Delta}/B_C)^{2n}}{2} \quad (\text{F.19})$$

For example, with $f_{\Delta} = 2B_C$ and $n = 3$, Equation (F.19) gives $10\log xy \approx 33.1$ dB, which is more than adequate. For the same parameters, Equation (F.16) gives $10\log(x_A y)_{\max} \approx 34.3$ dB for the square-notch approach. For $n = 2$ (and $f_{\Delta} = 2B_C$), $10\log xy \approx 21$ dB for the MC case, and $10\log(x_A y)_{\max} \approx 20.3$ dB for the square-notch case. It thus appears that the two approaches are comparable in terms of their ability to keep the target channel clear while blocking other channels.

F.5 Conclusions

For threshold testing using either the square-notch or the multicarrier approach, the key parameter is the achievable dB difference between the residual power from the interference generator on the target (unblocked) channel and the power on the blocked channels. This dB difference can be represented by

$$Z \triangleq X + Y = 10\log(xy) \quad (\text{F.20})$$

where

- X is the amount by which the interference power in the blocked channel exceeds the threshold under test,
- Y is the amount by which the residual power in the target channel falls below the threshold (in dB).

For the square-notch approach, Z on a frequency channel adjacent to the target channel is different from that on the other channels, and will be denoted by Z_A , which reaches its maximum value, denoted by $Z_{A\max}$, when the notch edges fall on the center frequencies of the channels adjacent to the target channel (i.e., $W_N = 2f_{\Delta}$). At that point, $Z_{A\max} = Z - 3$ dB. Note that $Z_{A\max} = 10\log(x_A y)_{\max}$. In the procedures that follow for setting up the out-of-operating-region interference, W_N will not be allowed to exceed $2f_{\Delta}$, so Z_A will always be within 3 dB of Z , for the square-notch case.

Given the EUT selectivity, $|H(f)|^2$, and the center frequency separation, f_{Δ} , $Z_{A\max}$ and Z are fixed. However, the generator power level can be adjusted to vary Y , subject to the constraints that $X_A + Y = Z_A$, $X + Y = Z$, and the fact that X_A (for the square-notch case) and X (for the multicarrier case) shall be sufficiently high to block the nontargeted channels.

F.6 Test procedures

The relationships developed here can be used to formulate a set of procedures for using MC and square-notch interference to test for thresholds, while preventing the test results from being biased by the residual interference power from the generator. The basic approach is as follows:

- In the MC case, find Z . In the square-notch case, find the notch width, $W_N \leq 2f_{\Delta}$, for which $Z = 25$ dB. If $Z < 25$ dB for $W_N = 2f_{\Delta}$, then find Z for $W_N = 2f_{\Delta}$. Z_A will be 3 dB less.
- Lower the interference to split Z between X and Y , where X shall be adequate to block the nontarget channels. Perform the threshold test(s) in the target channel(s). If $Y < 10$ dB, a correction factor shall be applied to the test results.

These general steps translate into the following specific procedures for square-notch and multicarrier interference.

F.6.1 Square-notch interference generator

F.6.1.1 Isochronous upper and asynchronous threshold

- a) Apply interference across the sub-band of interest at the maximum level, or at least 10 dB above the manufacturer's declared threshold. Lower the interference until the EUT can transmit. The interference is now at threshold.
- b) Raise the interference by 25 dB and open a spectrum window (notch) centered on the center frequency of the target channel. Increase the notch width until either the EUT can transmit or the notch edges fall on the center frequencies of the adjacent channels, whichever occurs first.
- c) If the EUT transmits before the maximum notch width is reached, note that $Z = 25$ dB for the current notch width. Lower the power by 15 dB. The residual power in the target channel is now 15 dB below the threshold (i.e., $Y = 15$ dB).
- d) If the EUT could not transmit with the notch edges at the center frequencies of the adjacent channels, lower the power until the EUT can transmit. Z is the dB difference between the generator PSD at that point and the threshold, and Z is 3 dB less. Lower the interference power by 15 dB or $Z - 6$ dB, whichever is less (this ensures that X_A is at least 3 dB). The amount of the reduction is Y . If Y is less than 10 dB, a correction factor shall be applied to the test results. If a test signal of a power level of S dBm causes deference, then the actual threshold is:

$$T = S - 10\log(1 - 10^{-Y/10}) \quad (\text{F.21})$$

The abscissa of Figure F.3 corresponds to $-Y$, and the ordinate corresponds to $S - T$ (the dB difference between the measured and actual thresholds).

Make note of the value of Z , the corresponding notch width, W_N , and the value of Y .

F.6.1.2 Isochronous lower threshold and least-interfered channel

- a) With the interference generator configured to apply interference on the frequency channels that overlap either the upper or lower 3 MHz of the band (depending on the emission bandwidth of the EUT), set the generator power level at the EUT (using attenuators if necessary) to a level that is 10 dB below the manufacturer's declared lower threshold. Verify that the EUT transmits on a channel that overlaps the 3 MHz at the appropriate end of the band. Raise the generator power level until the point is found at which the EUT transmits on a frequency that does not overlap the first 3 MHz. The generator PSD, relative to kT , is at the lower threshold.
- b) Open two notches in nonadjacent channels, each of a width, W_N (as determined above). Neither channel should overlap the 3 MHz at the preferred end of the band. For the lower threshold test, set the generator PSD to a level that is X dB above the lower threshold, where X is 6 dB or $Z - 15$ dB, whichever is greater, and Z is the value determined above. If Y is less than 10 dB, use the correction factor in Equation (F.21).
- c) For the least-interfered channel test, increase X to 15 dB and compute $Y = Z - 15$ dB. If Y is less than 7 dB, the test signal used in the least-interfered channel shall be adjusted such that the total power is 3 dB above the lower threshold. If S is the power of the test signal into the EUT, in dB above the lower threshold, then:

$$S = 10\log(2 - 10^{-Y/10}) \quad (\text{F.22})$$

F.6.2 Multicarrier interference generator

F.6.2.1 Isochronous upper and asynchronous threshold

- a) Apply interference on all system carriers at the maximum level. Lower the interference uniformly on all carriers until the EUT can transmit. This power level is the threshold.
- b) Raise the interference by 25 dB, and remove the interfering carrier on the target frequency. If the EUT can transmit, then $Z \geq 25$ dB. Reduce the power on all active carriers by 15 dB, so that $X = 10$ dB and $Y \geq 15$ dB, and proceed with the test. Make note of the fact that $Z \geq 25$ dB. If the EUT cannot transmit on the target frequency, perform the next step.
- c) Lower the power until the EUT can transmit on the target frequency. Note that Z is the dB difference between the carrier power at which the EUT can transmit and the threshold determined in step a).
- d) Reduce the interference power by 15 dB or $Z - 3$ dB, whichever is less. The amount of the reduction (in dB) is Y . The residual power in the target channel is now Y dB below the threshold. Proceed with the threshold test on the target frequency. If Y is less than 10 dB, the correction factor in Equation (F.21) shall be used to determine the threshold.

F.6.2.2 Isochronous lower threshold and least-interfered channel

- a) Establish interfering carriers on the center frequencies of all frequency channels that overlap either the upper or lower 3 MHz of the band (depending on the emission bandwidth of the EUT), and set the power level (per carrier) to 10 dB below the manufacturer's declared lower threshold. Verify that the EUT transmits on a frequency channel that overlaps the first 3 MHz at the appropriate end of the band. Raise the power on the interfering carriers until the point is found at which the EUT transmits on a frequency that does not overlap the first 3 MHz. The power level per carrier is at the lower threshold.
- b) Remove the carriers from two nonadjacent frequencies, neither of which overlaps the 3 MHz at the preferred end of the band. For the lower threshold test, set the power on the active interfering carriers to X dB above the lower threshold, where X is 3 dB or $Z - 15$ dB, whichever is greater, and Z is the value determined above. If Y is less than 10 dB, use the correction factor in Equation (F.21).
- c) For the least-interfered channel test, increase X to 12 dB and compute $Y = Z - 12$ dB. If Y is less than 7 dB, then the test signal, S , used in the least-interfered channel shall be adjusted per Equation (F.22).